

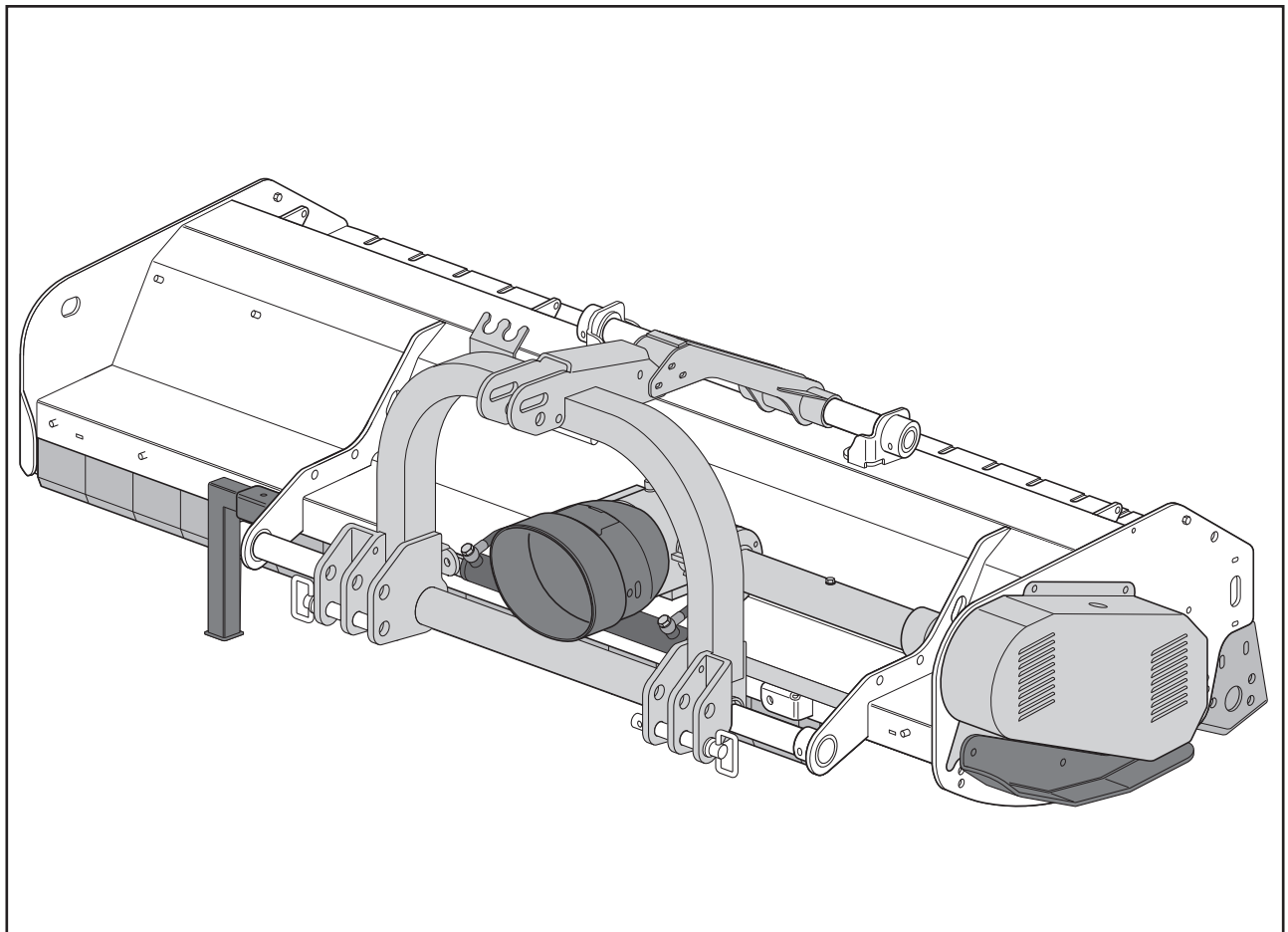

USER MAINTENANCE MANUAL - SPARE PARTS

TFB - SERIES



INDEX

1. INTRODUCTION	Pag.3
1.1 Features, validity and updates to the manual	Pag.3
1.2 Conservation of the manual.....	Pag.3
2. MAIN TECHNICAL DATA.....	Pag.4
2.1 Identification plate	Pag.4
2.2 Technical Features.....	Pag.4
2.3 Sound Level.....	Pag.5
2.4 Machine components description.....	Pag.6
2.5 Warning and danger signals	Pag.7
2.6 Adhesive warning and danger plates	Pag.7
3. ESSENTIAL REQUIREMENTS FOR SAFETY AND HEALTH PROTECTION	Pag.9
3.1 Machine use	Pag.10
3.2 Ergonomics	Pag.12
4. USER INSTRUCTIONS	Pag.13
4.1. Transportation methods.....	Pag.13
4.2. Prior to use	Pag.14
4.3. Adjustment of the sliders and roller	Pag.14
4.4. Application to the tractor	Pag.14
4.5 Cardan shaft.....	Pag.16
4.6 Adjustment of working height	Pag.18
4.7 Mower working position.....	Pag.18
4.8 How to work.....	Pag.19
4.9 Working.....	Pag.20
4.10 Storage.....	Pag.21
5. MAINTENANCE	Pag.22
5.1. Periodic maintenance.....	Pag.22
5.2. Lubricants.....	Pag.23
5.3. Hammers: use and replacement.....	Pag.23
5.4. Belts: use and replacement	Pag.26
5.5. Problems and solutions	Pag.27
5.6. Set-aside	Pag.27
5.7. Demolition of the mower	Pag.28
6. WARRANTY	Pag.28
7.SPARE PARTS	Pag.29

1. INTRODUCTION

The mower is designed to carry out maintenance operations in green areas, or cutting directly on the field, cutting branch tendrils, grass, straw, corn, tobacco, artichokes, beetroot, cotton and the residues from the pruning of orchards, vineyards and kiwi plantations into small pieces. This manual describes the user and maintenance instructions and the replacement parts supplied.

The manual is integral to the mower, defines the scope of the mower and contains all the information required for proper and safe use. The mower is designed for professional use and is only consented for specialised operators. The use by minors or people in abnormal physical or mental conditions is not allowed. The use by staff without driving licences or who are insufficiently informed or trained is not allowed.

The operator is responsible for the control of the working of the mower and the replacement and repair of parts subject to wear and tear which could cause damage.

The piece of agricultural equipment can only operate by means of a Cardan shaft applied to the power take-off of an agricultural tractor equipped with a lifting unit, with a 3-point universal hitch.

Proper operation of the machine depends on regular maintenance of the mower so it is advisable to follow the instructions carefully to prevent any inconvenience that could compromise the machine's operation and durability. It is especially important to follow the manual's instructions as the Manufacturer cannot be held responsible for negligent behaviour and non-compliance with these instructions.

The Manufacturer can however be contacted at any time for immediate and accurate technical assistance and anything required for optimum operation and maximum yield of the equipment.

1.1 Features, validity and updates to the manual

All technical material and descriptions in this manual are exclusively owned by BE who prohibits complete or partial reproduction unless written approval has been issued by the same.

Data, illustrations and descriptions in the manual cannot be considered binding. BE reserves the right to make changes at any time that it considers suitable for improvement or for a constructive or commercial requirement, without needing to update the manual immediately. The manual refers to the mower with the features and accessories mounted at the moment of supply. It also reflects the technical state at the moment of marketing of the mower and cannot be considered inadequate if updated at a future date following new experiences.

1.2 Conservation of the manual

The manual should be carefully stored in an area suitable for correct conservation to guarantee its physical integrity; it should be easy to access for anyone authorised to consult it. The manual is an important document that should accompany the mower and all users should be held responsible for safeguarding it.

2. MAIN TECHNICAL DATA

2.1 Identification plate

Each mower is labelled with an identification plate specifying the main technical and identification data: the plate is secured to the structure of the mower in a position where it is easy to find and read.

Data on the identification plate safely defines the mower and its features, certifying its compliance with current legislation.

For this reason **it should never be removed or used for other purposes**. If the mower is dismantled, it should be destroyed to avoid any form of abuse.

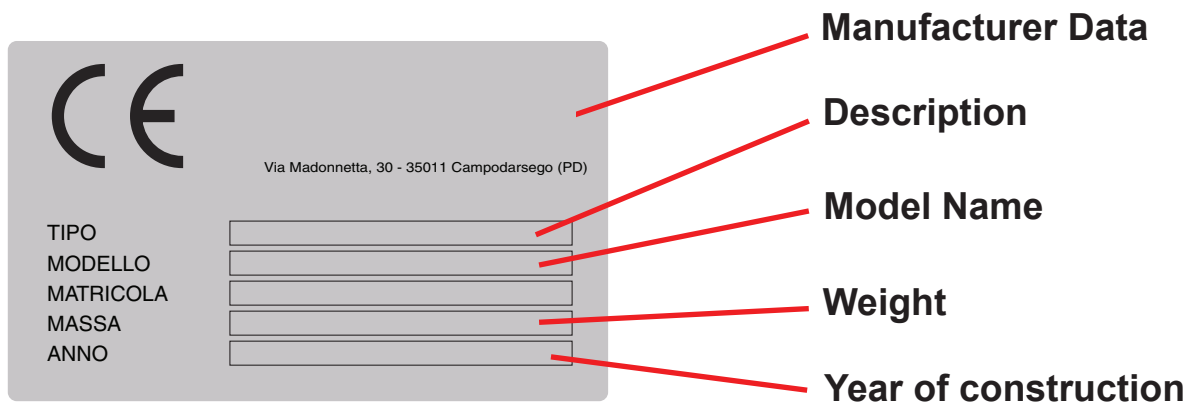

Data on the manufacturer's plate should always be referred to when requesting assistance and/or supply of spare parts.

2.2 Technical Features

- | | |
|--------------------------------|---|
| - Hitch to the tractor: | 3-point universal |
| - No. enter revolutions : | 540g 1' (1000g 1' on request) |
| - Primary transmission: | Cardan shaft |
| - Secondary transmission: | Belts |
| - Cut height adjustment: | Mechanical |
| - Lateral movement adjustment: | Mechanical, hydraulic on request |

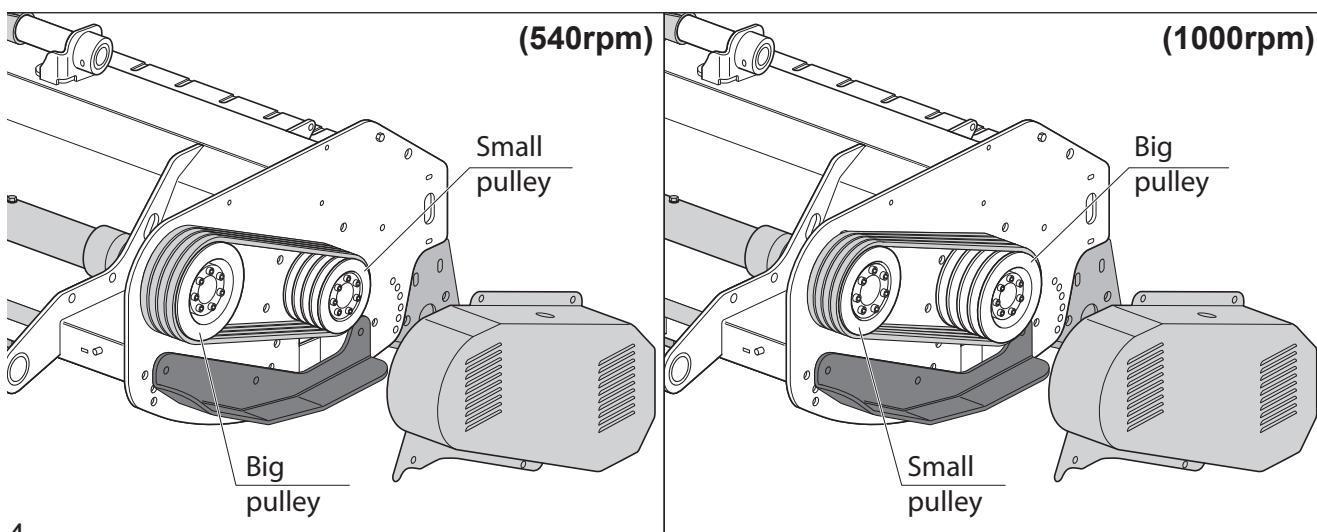

Model	Work Cm.	HP Power requested	No. hammers	Weight KG	Dimensions (W x L x H) cm.
TFB 1200	120	30 - 40	10	440	143x132x83
TFB 1400	140	35 - 60	12	510	162x132x83
TFB 1600	160	40 - 70	14	570	186x132x83
TFB 1800	180	50 - 70	16	610	205x132x83
TFB 2000	200	60 - 80	18	680	224x132x83
TFB 2200	220	70 - 90	20	750	243x132x83
TFB 2400	240	80 - 100	20	800	262x132x83
TFB 2600	260	90 - 100	22	850	281x132x83
TFB 2800	280	90 - 110	24	920	300x132x83
TFB 3000	300	110 - 150	26	990	319x132x83

2.3 Sound Level

Testing of noise of the mower on its own from the operator position (ISO,1680/2):

Level of acoustic pressure:

LpAm (A) dB **100.1**

Level of acoustic power:

LwA (A) dB **114.6**

2.4 Machine components description

TFB Model

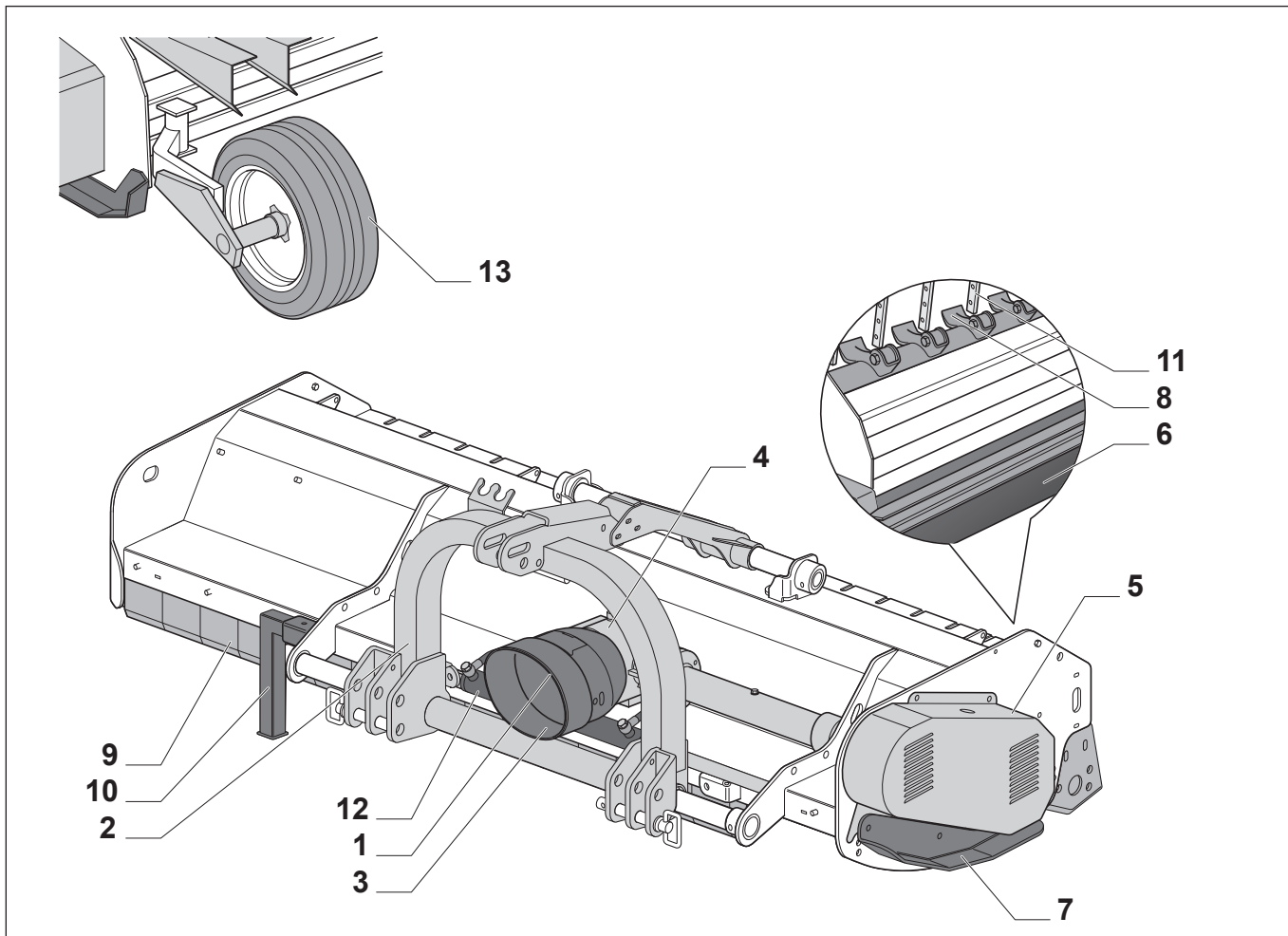

(Fig.1)

- 1 - Power take-off hitch
- 2 - Three point coupling
- 3 - Cardan protective casing
- 4 - Gear box with free wheel
- 5 - Lateral transmission belt
- 6 - Leveller roller
- 7 - Sliders (on request)
- 8 - Hammers
- 9 - Accident prevention protection
- 10 - Support foot
- 11 - Branch tendril collection rod (on request)
- 12 - Lateral movement
- 13 - Steering wheels (on request)

2.5 Warning and danger signals

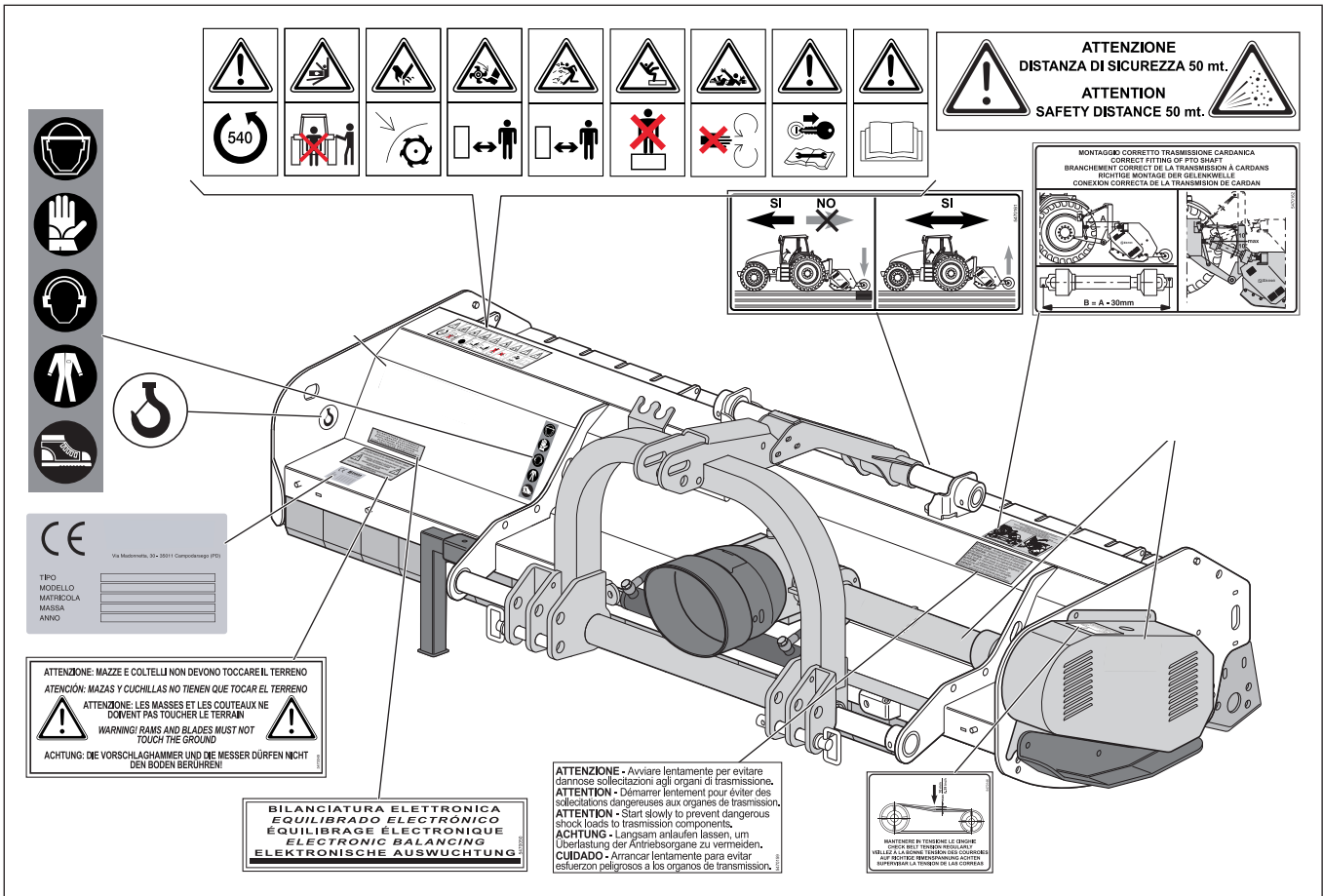

(Fig.2)

2.6 Adhesive warning and danger plates







Each mower is equipped with an identification plate, which shows:

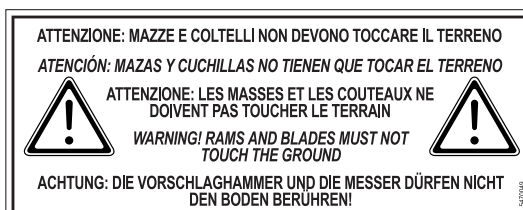

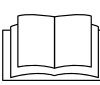

- Manufacturer's stamp.
- Manufacturer's name, trade name and address.
- Type of mower.
- Model of mower.
- Weight in Kg.
- Year of construction.
- CE stamp.

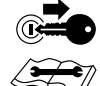

Plates with indications and particular warnings for maintenance and a correct use of some parts of the machine. The respect of these plates lengthens the duration and the efficiency of the Mower.



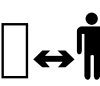

 	<p>Read the user and maintenance manual with care prior to starting up the machine.</p>	 	<p>Risk of cutting off feet. Keep at a safe distance. Do not remove protections before halting and disconnecting the machine.</p>
--	---	--	---

 	<p>Always disconnect the machine from the tractor immediately, prior to starting any maintenance and/or lubrication work.</p>	 	<p>Risk of cutting off hands. Keep at a safe distance. Do not remove protections before halting and disconnecting the machine.</p>
--	---	--	--

 	<p>Risk of falling. It is prohibited to climb onto the machine.</p>	 	<p>Risk of entanglement in the Cardan shaft. Keep away from moving parts.</p>
--	---	--	---

 	<p>Risk of ejected objects. Keep a safe distance.</p>		<p>Use personal protection devices.</p>
	<p>Lifting point.</p>		

 <p>ATTENZIONE: DISTANZA DI SICUREZZA 50 MT. ATENCIÓN: DISTANCIA DE SEGURIDAD 50 M. ATTENTION: DISTANCE DE SÉCURITÉ 50 M. WARNING! SAFETY DISTANCE = 50 M. ACHTUNG: SICHERHEITABSTAND 50 MT.!</p> 	<p>Keep clear from the moving machine; keep at a safe distance. Keep away from moving parts.</p>
---	--

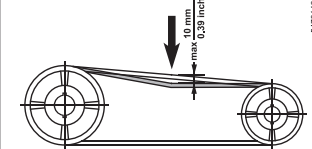

MANTENERE IN TENSIONE LE CINGHIE
 CHECK BELT TENSION REGULARLY
 VEILLEZ À LA BONNE TENSION DES COURROIES
 AUF RICHTIGE RIMENSPPANNUNG ACHTEN
 SUPERVISAR LA TENSION DE LAS CORREAS

Indicates the maximum movement (1cm = 5Kg) of belt adjustment for correct transmission.

MONTAGGIO CORRETTO TRASMISSIONE CARDANICA
 CORRECT FITTING OF PTO SHAFT
 BRANCHEMENT CORRECT DE LA TRANSMISSION À CARDANS
 RICHTIGE MONTAGE DER GELENKWELLE
 CONEXION CORRECTA DE LA TRANSMISION DE CARDAN

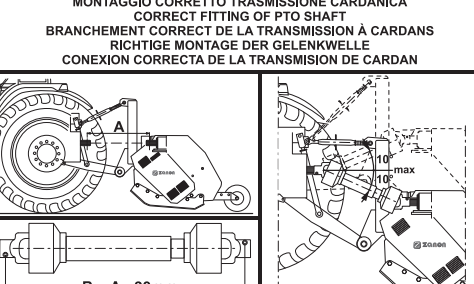

B = A - 30mm

Indicates the correct functioning of the Cardan shaft.

3. ESSENTIAL REQUIREMENTS FOR SAFETY AND HEALTH PROTECTION



WARNING!

This danger symbol, used throughout the manual, stands for any standard that could compromise your safety and that of other people and the working order of the mower.

There are three levels of danger signals:

DANGER: this signal warns that if the described operations are not carried out properly, they will cause serious injury, death or long-term health risks

WARNING: this signal warns that if the described operations are not carried out properly, they can cause serious injury, death or long-term health risks

CAUTION: this signal warns that if the described operations are not carried out properly, they can cause damage to the mower.

In order to complete the various levels of danger, situations and specific definitions which can directly involve the machine of persons are described below (according to Directive 2006/42/CE).

HAZARDOUS AREA: Any area in and/or around a machine where the presence of an exposed person constitutes a risk to the health and safety of said person.

EXPOSED PERSON: A person fully or partly in a hazardous area.

OPERATOR: The person or personnel in charge of the installation, the operation, the adjusting, the cleaning, the repairing and the moving of the machine.

RISK: a combination of the probability and seriousness of the injury or damage to health which can arise in a dangerous situation.

GUARD: a part of the machine consisting of a material barrier specifically used to guarantee protection.

PROTECTION DEVICE: is a device that reduces risk (unlike the guard) either on its own or together with the protection.

INTENDED USE: the use of the machine in accordance with the information provided in the operating instructions.

REASONABLE FORSEEABLE MISUSE: the use of the machine differently from the information provided in the operator's instructions, which may be the result of readily predictable human behaviour.

USER: The person, entity or company which had purchased or rented the machine and intends to use it for its intended purpose.

SPECIALISED STAFF: These are specially trained staff able to carry out any maintenance or repair work requiring specific knowledge of the machine, its operation, safety devices and intervention methods and can understand and therefore avoid hazards associated with the use of the machine.

AUTHORISED ASSISTANCE CENTRE: The Authorised Assistance Centre, legally au-

thorised by the Manufacturer, is formed by specialised staff able to carry out all types of assistance, maintenance and repair work, even of a certain complexity, required to maintain the machine in perfect working order.

Read all the instructions carefully prior to using the machine. If you have any doubts, contact the Manufacturer's Concessionaries' technicians.

The Manufacturer declines all responsibility for non-compliance to the safety and accident-prevention regulations described below.

3.1 Machine use

- 1) Take note of hazard symbols in this manual and on board the mower.
- 2) Strictly comply with all accident-prevention measures recommended and described in this manual.
- 3) Avoid touching moving parts in operation at all costs.
- 4) All interventions and adjustments should always be carried out at machine standstill.
- 5) It is absolutely prohibited to transport persons or animals.
- 6) It is strictly prohibited to allow staff that are unsuitably trained, unauthorised or in poor health to drive the tractor or have it driven, with the mower applied.
- 7) The application of the mower onto the tractor leads to a different distribution of weights on the axles. It is therefore advisable to add appropriate ballasts in the front part of the tractor in order to share out the way adequately over the axles.
- 8) The mower applied can only be controlled with a Cardan shaft complete with the necessary safety measures.
- 9) Prior to starting the tractor and the mower, check the perfect integrity of all the safety devices for transport and use.
- 10) Labels providing instructions on the mower provide essential advice on how to avoid accidents: follow the advice carefully.
- 11) For driving on roads, it is necessary to conform to the current highway code regulations in the respective country.
- 12) Road transport occurs under the total responsibility of the user, who must verify the conformation to the current highway code in the country of use.
Respect the maximum weight provided for on the tractor axle, the total mobile weight, the regulation on transport and the highway code.
- 13) Prior to starting work, familiarise yourself with the control devices and their functions.
- 14) Use suitable clothing: avoid long or loose clothing that could be caught in any way by moving parts.
- 15) Couple the mower to a tractor with adequate power, weight and configuration using the appropriate device (lifter), conforming to regulations.
- 16) Pay great attention during the coupling and decoupling of the mower.
- 17) Never leave the driving seat when the tractor is running.
- 18) Bear in mind that the road holding, breaking and directionality of the tractor can be influenced, even in a noticeable way, by the presence of the mower.
- 19) Prior to inserting the power take-off, make certain of the number of preset revolutions (540rpm): do not confuse the 540rpm speed with the 100rpm speed.
- 20) It is strictly prohibited to stand in the working area of the mower, where there are moving parts.

- 21) Prior to abandoning the tractor, lower the mower coupled to the lifting unit, halt the engine, put on the emergency brake and remove the ignition keys from the control panel.
- 22) It is strictly prohibited to stand in the middle of the mower with the engine on and the Cardan shaft without having put on the emergency brake and inserted a piece of wood under the wheels. Keep a safe distance from the running mower because of possible ejections of dangerous objects (50m to the rear)
- 23) Prior to coupling or decoupling the mower to/from the three point hitch, place the lifter control lever in a locked position.
- 24) The category of hitch pins of the mower must correspond to that of the lifter hitch.
- 25) During road transportation, with the mower lifted, place the control lever of the tractor's hydraulic lifter in a locked position. During lifting from the ground, the joints of the Cardan shaft are folded at more than 40° (power take-off idle); disconnect the shaft from the tractor's power take-off.
- 26) Only use the Cardan shaft provided for by the manufacturer.
- 27) Periodically check the protections of the Cardan shaft which must always be in excellent condition and firmly secured.
- 28) Prior to inserting the power take-off, make sure that there are no people or animal in the working area and that the speed chosen corresponds to that permitted. Do not exceed to maximum allowed.
- 29) Do not insert the power take-off with the engine switched off.
- 30) Always disconnect the power set-up when the Cardan shaft makes an angle which is too open (never more than 10°) and when not in use.
- 31) When not needed, rest the Cardan shaft on the support provided.
- 32) After dismantling the Cardan shaft, replace the protective cap on the power take-off shaft.
- 33) The prolonged use of the mower can, as a secondary effect, cause the heating of the multiplier box and eventual elements of the hydraulic circuit: avoid touching these elements for risk of burns.
- 34) Respect the conformity of the recommended oils.
- 35) Spare parts must correspond to the needs defined by the Manufacturer: only use original spare parts.



ATTENTION

If using a tractor without a sound-proofed cabin, it is necessary for the operator to use protection systems:

- Ear protection for the noise, if it exceeds regulated exposure levels.
- Antidust mask if, due to the type of work (dusty ground), a large quantity of dust is raised.

3.2 Ergonomics

In the prescribed operating conditions, the discomfort, fatigue, psychological stress and physical stress of the operator must be reduced as much as possible by taking into account the following ergonomics principles:

- consider the difference in physical dimensions, the strength and the stamina of the operator;
- the operator must have enough space for body movement;
- the work rhythm should not be dictated by the machine;
- avoiding monitoring that requires lengthy concentration;
- adapt the man to the machine interface to suit the operators foreseeable characteristics.

4. USER INSTRUCTIONS

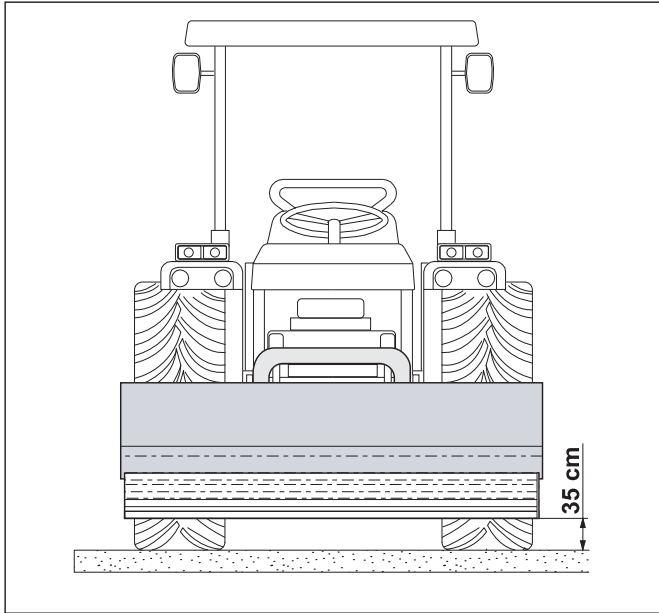

(Fig.3)

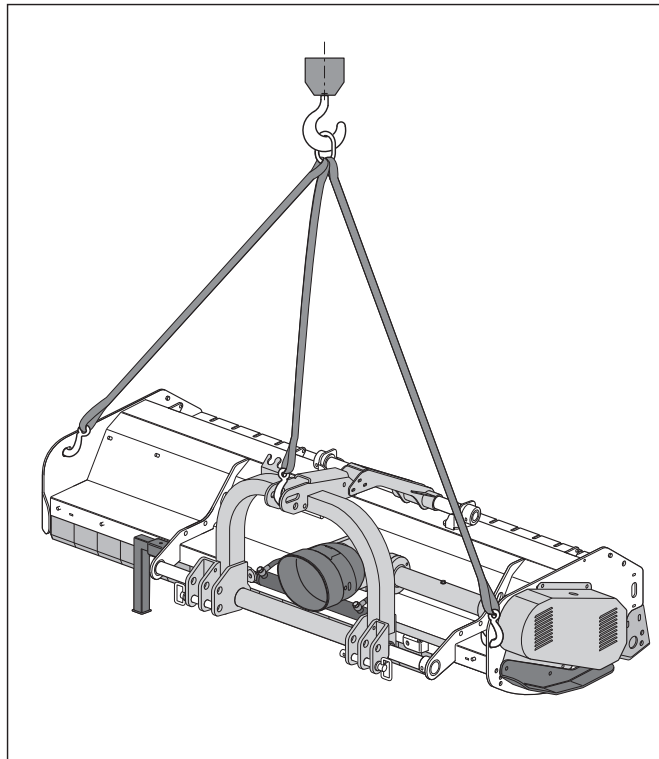

(Fig.4)

4.1. Transportation methods

During transportation and any time when it becomes necessary to lift the mower, it is necessary to adjust the tractor lifting unit so that the mower itself is lifted about 35 cm from the ground (Fig. 3).

It is also necessary to verify that all the locking devices are activated and that the mower is in the central position.

The movement of the mower not connected to the tractor must be carried out as shown in figure 4.

The manufacturer declines all responsibility for damage caused by movement which is different from that described above.

For transport on wagons, make sure that the mower is well anchored to the ground with regulated ropes or belts, keeping to the indications in paragraph 4.10.



ATTENTION

Tractors fitted with equipment which is not foreseen by the Highway Code, are classified as special type vehicles and must be authorised for road use.

Agricultural machines are classified as special type vehicles when the width ranges from **2,56 mt** to **3,20 mt** (mod. **TFB 2400, 2600, 2800 and 3000**).

The authorisation for road use (valid for one year and renewable) is issued by:

- the National Road Board of the town in which the journey starts as regards the national road network;
- the region as regards the rest of the road network.

Machines wider than **3,20 mt**, in addition to authorization, must have a technical escort. This can be provided by vehicles available on the farm. The escort vehicle must precede the vehicle by 75 to 150 m and be equipped with a blinking yellow or orange light. The driver must use a red flag to signal the presence of the wide vehicle following it.

4.2. Prior to use

Prior to starting up the mower, carry out the following operations:

- Check that the mower is in perfect working order, that the lubricants are at the right level (see "MAINTENANCE" chapter) and that all the pieces subject to wear and tear and deterioration are fully efficient.
- Check that the desired working height is well-regulated.

4.3. Adjustment of the sliders and roller

Adjust the position of the lateral sliders and the stationary roller so that the cutters do not come out of the plane made by the two sliders.

In this way, even if there are irregularities in the ground, the cutters will not penetrate the ground itself. It is important to check that the mower is perfectly parallel to the ground in order to obtain perfect operation.

The adjustment must be carried out using the third point **-Tp-** of the tractor (**Fig.5**).

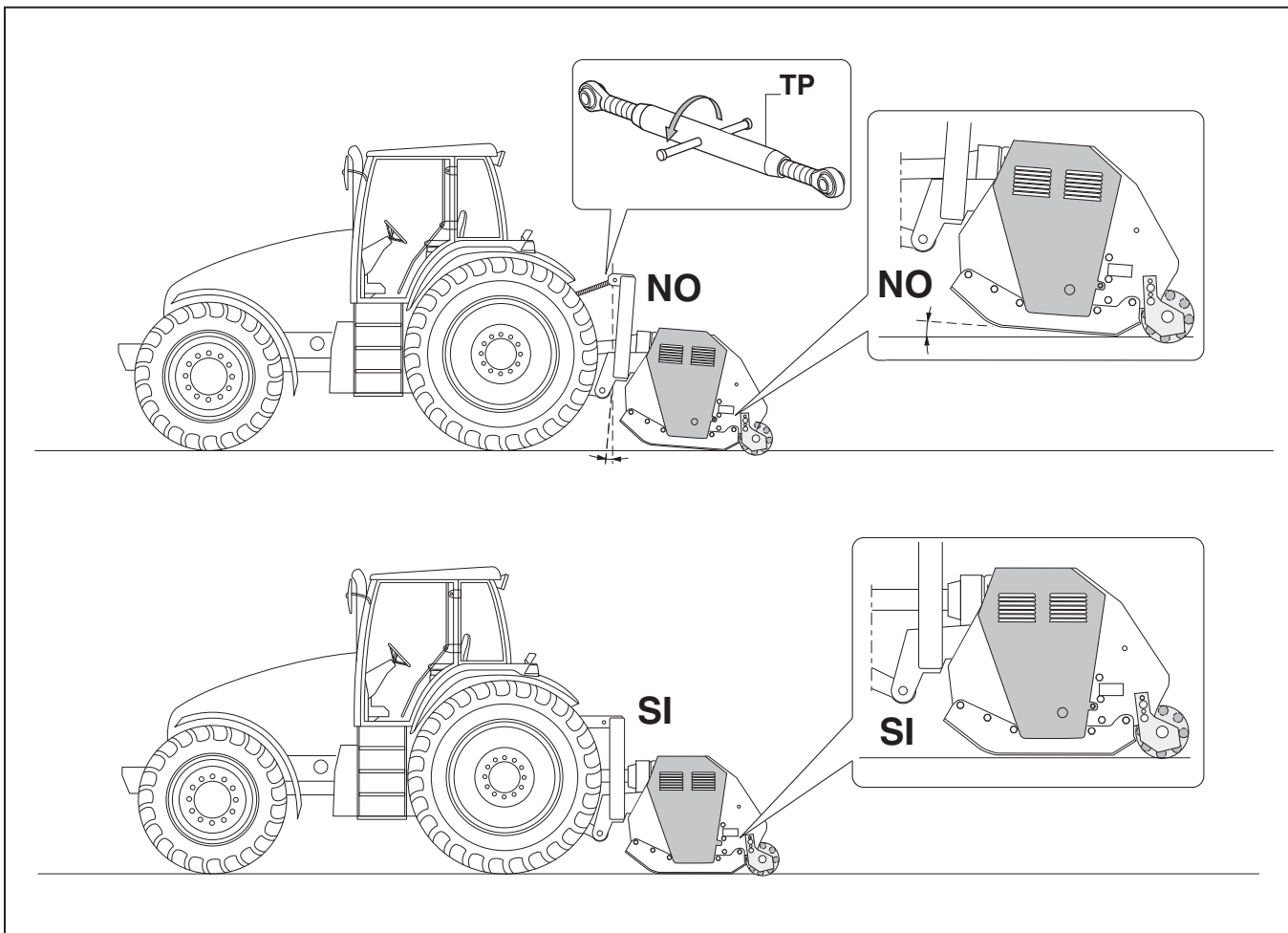

(Fig.5)

4.4. Application to the tractor

The application of the mower to the tractor must take place on flat ground. All the cutters are applicable to any tractor equipped with a universal three-point hitch.

The Manufacturer declines all responsibility for the breakage of the tractor.

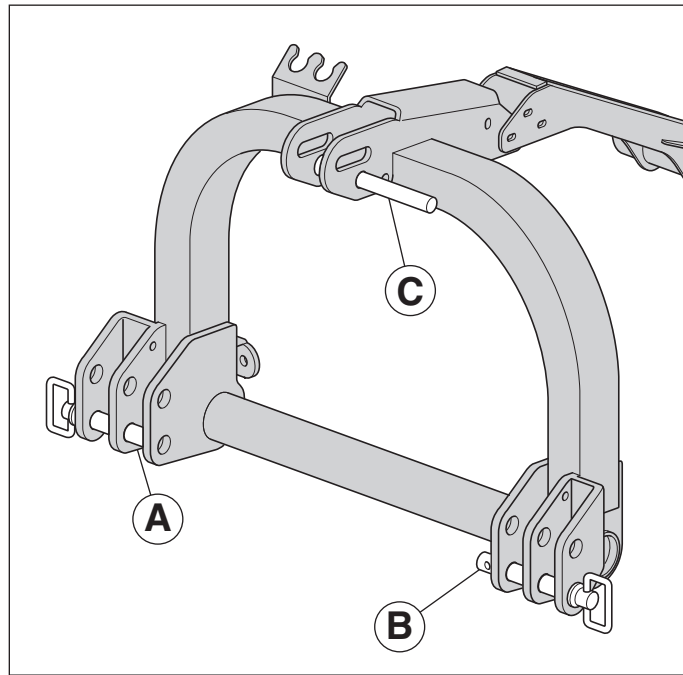

(Fig.6)



DANGER

The application to the tractor is a very dangerous phase: pay great attention and carry out the operation following the instructions.

The Manufacturer declines all responsibility for the breakage of the mower or the tractor resulting from the lack of respect of these indications.

The correct position of the tractor/mower is determined by placing the mower at a distance such that the Cardan shaft is extended 5-10cm from the position of maximum closure.

At this point proceed as follows:

1. Bring the lifter bars up close, placing them inside plates (A) and (B) (Fig.6). Insert the pin in the prepared hole and lock it with split pins.
2. Lock the lifter bars on the tractor with the appropriate chains and parallel tighteners: this precaution must take place in order to avoid any transversal movement of the mower.
3. Engage the Cardan shaft and make sure that it is perfectly locked on the power take-off. Verify that the protection rotates freely and secure it with the appropriate chain. Remove the support from the Cardan shaft.
4. Connect the high point (C) and carry out the correct adjustment with the tie-rod, verifying that the upper plane of the mower is parallel to the ground. This is very important in order to obtain parallelism between the cutter power take-off shaft axle and the tractor power take-off. Operating in these conditions means limiting the stresses on the power take-off and prolonging the duration of the Cardan shaft and the mower itself.



ATTENTION

Lift the shearing machine up from the ground and record the cutting height (see 4.6). Adjust the set up of the mower with the lifter, making sure that the mower is horizontal or a little higher at the back in order to favour the entry of the material.

4.5 Cardan shaft

The angulation at which the Cardan shaft works must be the minimum possible (10°): this favours the duration of both the shaft and the mower (Fig.7).

N.B.: While purchasing the Cardan shaft, for correct dimensioning always specify the power necessary to use the mower.



CAUTION

Read the instruction booklet that the Manufacturer of the Cardan shaft applies to it carefully. If worn or broken it must be replaced with a Cardan shaft marked EC.



CAUTION

The Manufacturer of the Cardan shaft recommends not to modify it: as the Cardan shaft is a part which rotates at a high speed, during testing it is subjected to balancing and eventual modification interventions could cause a lack of balance which would have repercussions on the operation of the cutter as well as on the integrity of the Cardan shaft itself.

When the Cardan shaft is extended at the maximum level in all working conditions the telescopic tubes must overlap for at least 1/3 of their length as in (Fig.7).

When it is inserted at the maximum level, the minimum clearance should be 4cm.

If this is not possible, contact the Technical Service of the Manufacturer.

Prior to starting to operate, verify that the appropriate safety chains are present in order to prevent the protections rotating solidly with the Cardan shaft and that they are in excellent condition.

Also check that the Cardan shaft is suitable for transmitting the required power for the mower. If you have any doubts, contact the Manufacturer.



CAUTION

Prior to inserting the power take-off, make sure that the rotation speed corresponds to that expected by the shearing machine (540/1000 rpm).

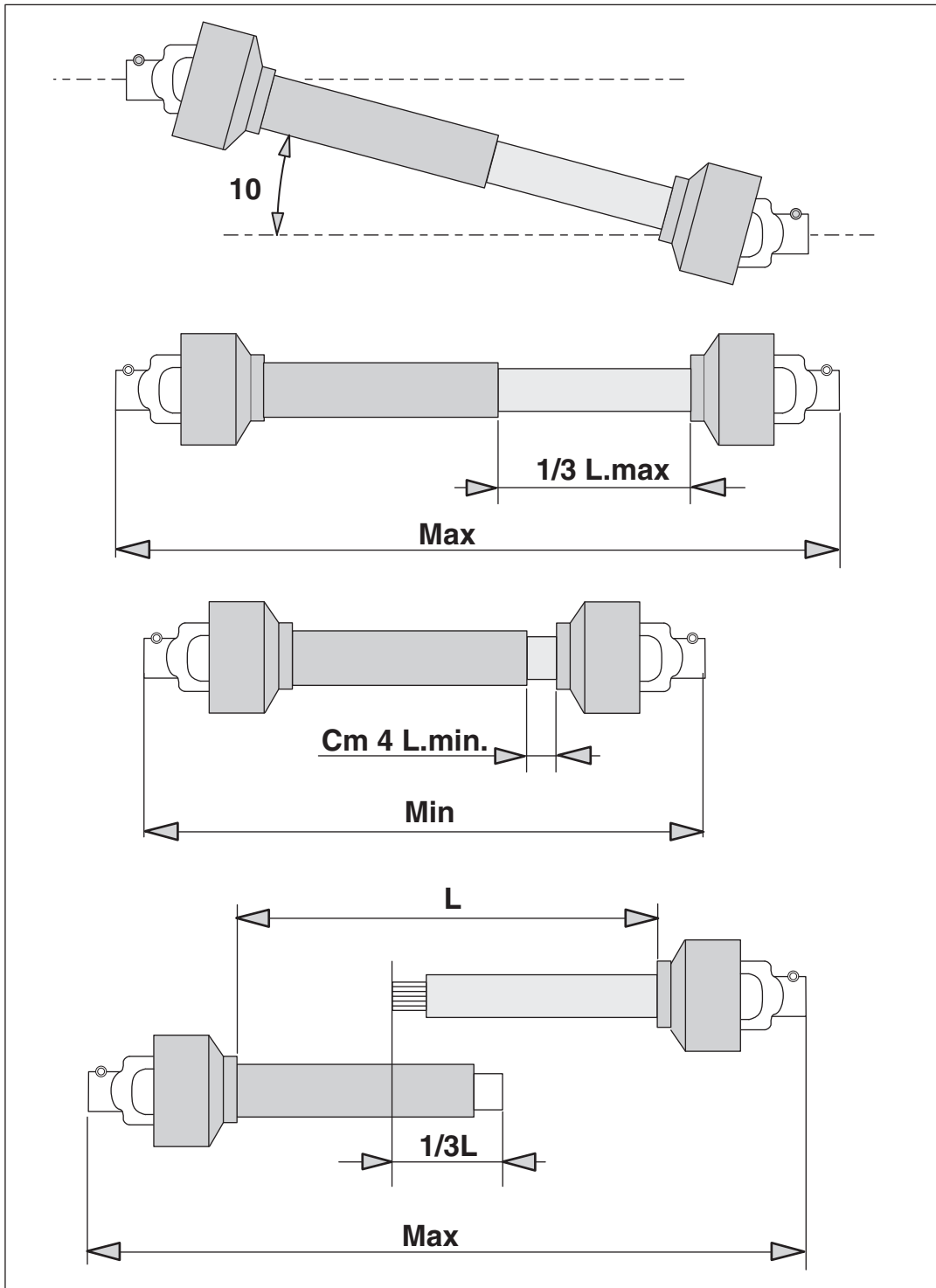

(Fig.7)



ATTENTION

The mower, being equipped with a freewheel in the transmission box, can also be applied to a tracked tractor or one without double clutch without the danger that the inactivity of the rotor prevents the mower tractor compound from stopping quickly.

4.6 Adjustment of working height

To adjust the working height, raise or lower the support sliders and the idle roller until obtaining the desired position.

To correctly adjust the working height of the mower, it is necessary:

- To gradually and completely lower the mower, with the tractor off and the emergency brake on, using the lifter, to ground level.
- Adjust the working height so that the cutters are at about **3 - 4cm (Fig.8)** from the ground.

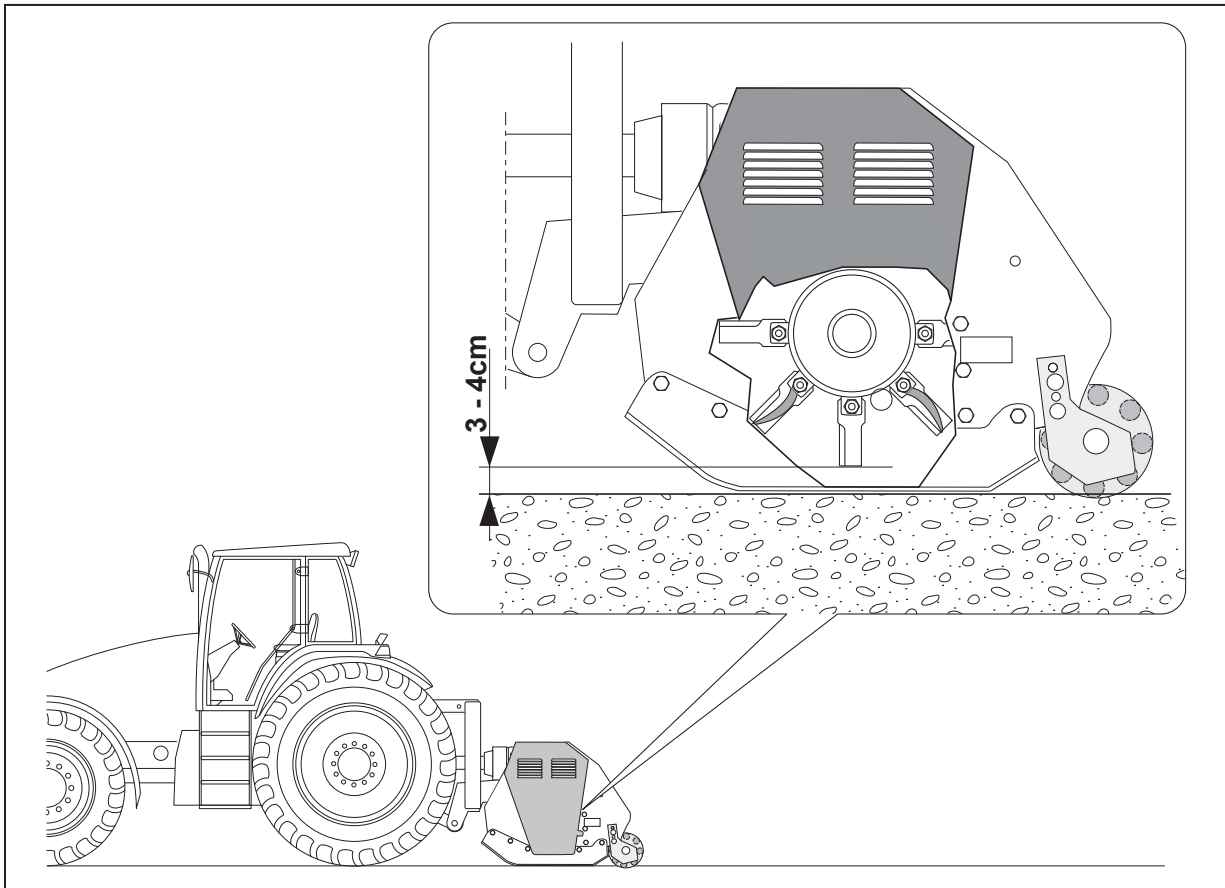

(Fig.8)

4.7 Mower working position

It is possible to work with the mower both in a lateral and central position according to requirements.

The machine is already equipped with a mechanical lateral movement which can be replaced with a hydraulic one on request. To adjust the position manually, remove the locking bolt, position the mower in the desired position and lock it with the bolt removed at the start of the operation.

If the cutter is equipped with a jack for lateral movement, once coupled to the tractor, connect the hydraulic tubes to the appropriate hitches of the tractor's hydraulic circuit.

Using the appropriate lever, the movement of the desired mower can be determined from the driving seat.

In all cases, movement must be carried out horizontally on the working plane with the mower slightly lifted off the ground.

Model	HP Power required	Movement (cm)	
TFB 1200	30 - 40	76 46	68 98
TFB 1400	35 - 60	76 46	87 117
TFB 1600	40 - 70	95 55	88 128
TFB 1800	50 - 70	95 55	107 147
TFB 2000	60 - 80	111 71	109 149
TFB 2200	70 - 90	132 92	111 151
TFB 2400	80 - 100	132 92	130 170
TFB 2600	90 - 100	157 117	124 164
TFB 2800	90 - 110	148 117	143 183
TFB 3000	110 - 150	172 132	147 187

4.8 How to work



When working, the inspection hood must be closed.

Start work with the power take-off running, gradually lowering the mower onto the ground. Avoid pressing the accelerator pedal rashly with the power take-off inserted and the mower off: this operation could be dangerous for the mower or for the tractor. The grinding of the material worked on is obtained with a slow advancing tractor speed and with the rotation of the running rotor.

New system of helical cut

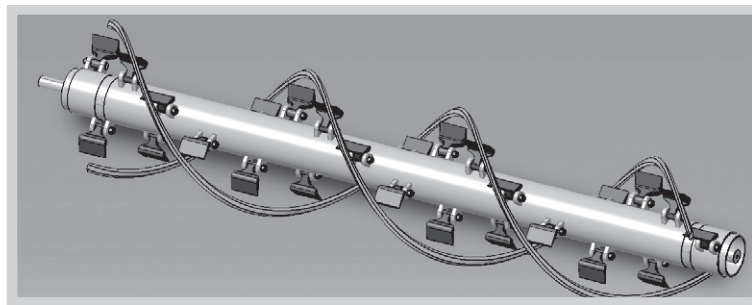

The roller is made up of eight rows of hammers arranged in a spiral for a more precise cut and uniform.

4.9 Working

After having carried out all the operations described previously, start up the tractor, disconnect the emergency brake. With the engine running low, insert the power take-off and start working. Little by little, as the tractor moves forwards, progressively and gradually lower the mower to the level of the ground and start the engine running.



CAUTION

The speed of the tractor with the mower working must never exceed 5km/h in order to avoid breakage or damage.



DANGER

While working it is possible that stones or other objects are lifted up by the rotating cutters: constantly check that there are no animals or people in the range of action of the mower (Fig. 9).

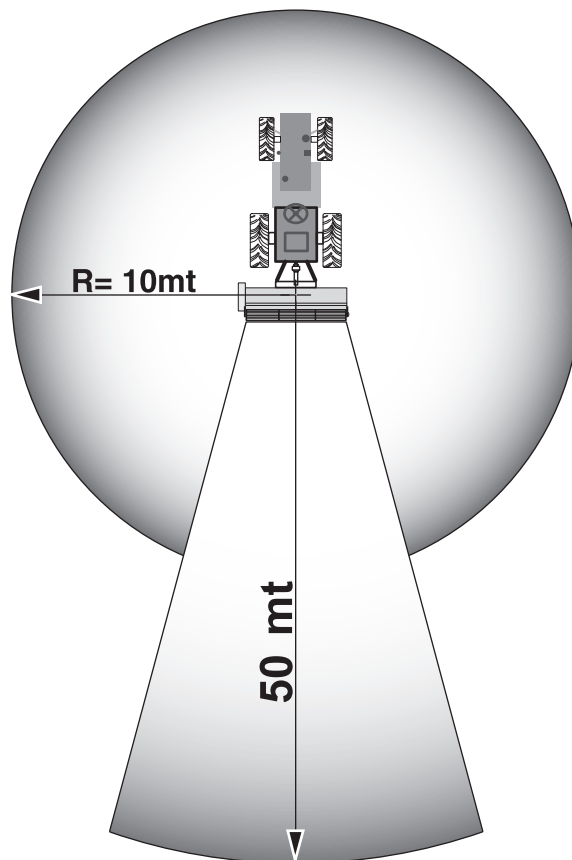

(Fig.9)



CAUTION

Avoid letting the mower rotate idly. During work, avoid making bends with the mower lowered and do not work in reverse.

Always lift up the mower before changing direction or doing U-turns.

During transportation and any time when it becomes necessary to lift the mower, it is necessary to adjust the tractor lifting unit so that the mower itself is lifted more than about 30-35cm from the ground

Avoid driving on public roads when the mower is dirty with earth, grass or at any time when it produces dirt or obstructs the traffic on the roads.

4.10 Storage



AVVERTENZA

In order to ensure stability to the mower when it is decoupled from the tractor it is necessary to follow some indications: (see **Fig.10**)

1. Make sure that the mower is deposited on a suitable flat surface without obstructive material.
2. Lower the mower to ground level.
3. Lift the back wheel so that the mower rests on the sliders using the third point.
4. In storage position use the appropriate support feet.

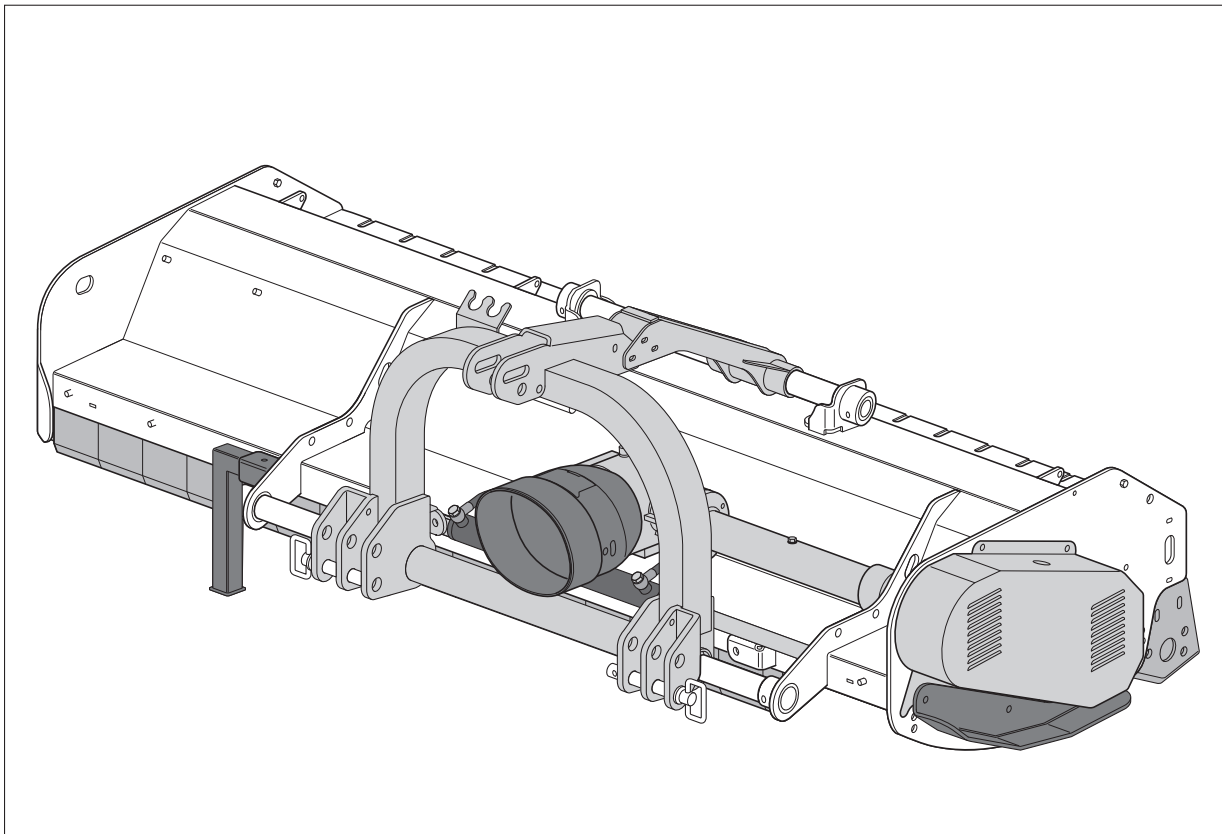

(Fig.10)

5. MAINTENANCE

5.1. Periodic maintenance

Regular maintenance and checks are required to ensure the machine is in good working order and the safety of the operator (see table below).

	First use	First 8 hours of operation	Every 8 hours of operation	Every 50 hours of operation	Every 400 hours of operation
General check	■	■			
Tightening of screws and bolts	■	■	■		
Checking for wear and tear on cutters, hammers and their locking screws	■		■	■	
Greasing spiders and Cardan shaft	■				
Greasing rotation points	■		■		
Verify multiplier box oil level	■			■	
Complete change of multiplier oil	■				■
Check transmission belt tension	■		■		

Maintenance of the hydraulic system



ATTENTION

Replace the hydraulic pipes when damaged and in any case within and no later than 6 years.

Used hydraulic oil must be duly recovered and must not be released into the environment because according to the laws in force it is classified as hazardous waste and must therefore be taken to special collection centres. Contact your nearest used oil consortium.

5.2. Lubricants

For the transmission box (1), **SHELL OMALA 220** or equivalent responding the **API – GL5/MIL-L-2105C** specifications is recommended

The quantity of oil is **1.2 litres** : do not exceed the prescribed quantity.

For all greasing points (2) and (3), **SHELL RETINAX WB 2 GREASE** or equivalent is recommended

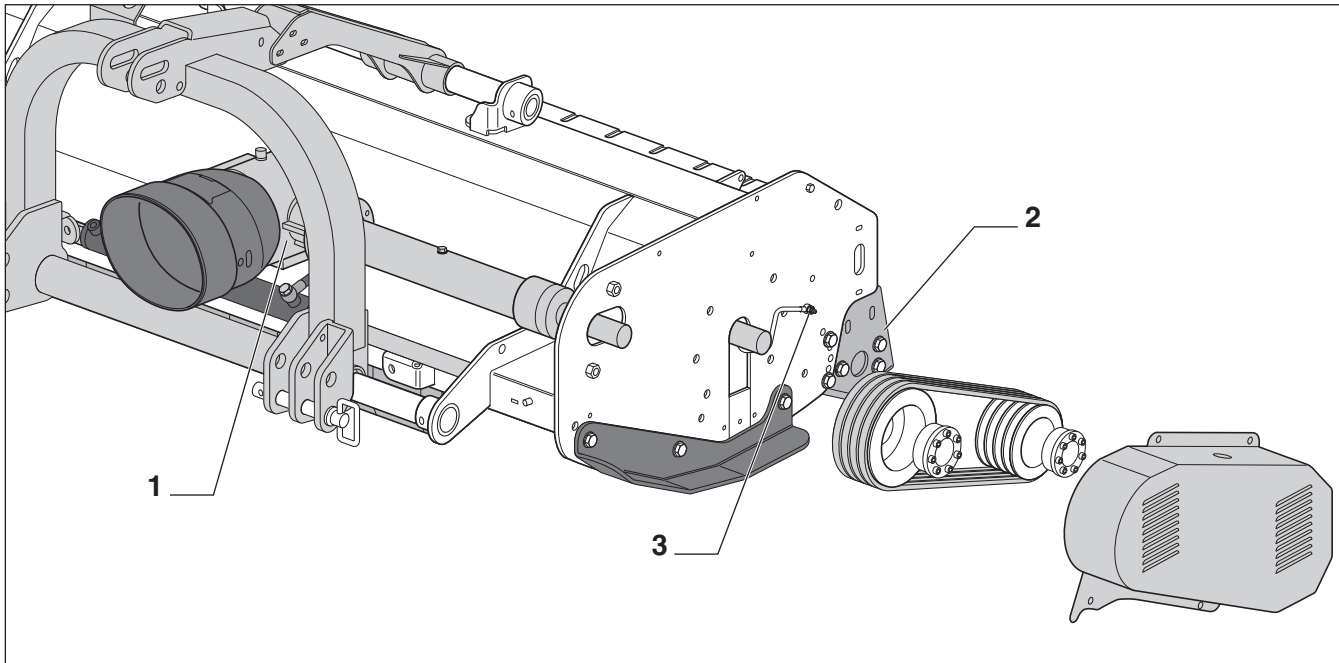

(Fig.11)



WARNING

For the disposal of used oils, conform to the respective anti-pollution laws in the country of use.

5.3. Hammers: use and replacement

The hammers with which the mower is equipped are suitable for working on grounds of normal conformation.

Check their wear and tear and integrity daily; if, during working, they should accidentally bend or break, it is necessary to replace them immediately. The replacement of a single hammer may only be carried out if all the other tools are in excellent condition and only if the opposing tool is also replaced in order to balance out the weight. **Replacing all the tools and not only those damaged is always recommended.**

However, after replacement is complete the roller must be electronically balanced to ensure that the machine is not subject to any vibrations that may cause severe damage.



The BE is not liable for damages caused by vibrations generated by shredding rollers whose hammers or blades have been replaced and then not balanced; therefore, requests for replacement under warranty or reimbursements for damaged caused will not be accepted.

To replace worn or broken hammers it is necessary to:

- position the mower and tractor on flat ground;
- raise the mower with the lifter to the maximum height possible;
- position sufficient support stands on both sides under the mower;
- halt the tractor and put on the emergency brake;
- be equipped with adequate keys and proceed with the replacement of the hammers: forcibly tighten the securing screws;
- weigh the blocks of hammers, because differences in weight are inevitable, and select pairs of the same weight: mount these pairs on the rotor in diametrically opposite positions.

The quality, integrity of the mower and its safety depend on the care dedicated to the hammers, which must be replaced immediately if damaged.

Normal wear and tear, particularly quick on sandy ground or working with the mower too low and collisions with obstacle can cause distortions or cracks in the hammers, which can cause the deterioration in the quality of work, increase in vibrations, with possible damage to the mower, partial or total breakage of the hammers with consequent projection of fragments at high speed.

The pin hole of the hammer must not be ovaled more than **2mm** from the original diameter.

For worn hammers (see Fig. 12):

- The length of the hammer must not be less than the size indicated in the figure.
- The securing with pins can be carried out with nuts: the nuts must be changed every time a hammer is replaced; the tightening couple is **250 Nm**.

Special screws for securing hammers.

- If they are visibly damaged, bent or ovaled to the limit, as shown in (**Fig. 12**), it is necessary to replace them.
- When finished, remove the support stands, start up the tractor, lower the mower and turn off the tractor.



CAUTION

Only use original spare parts.

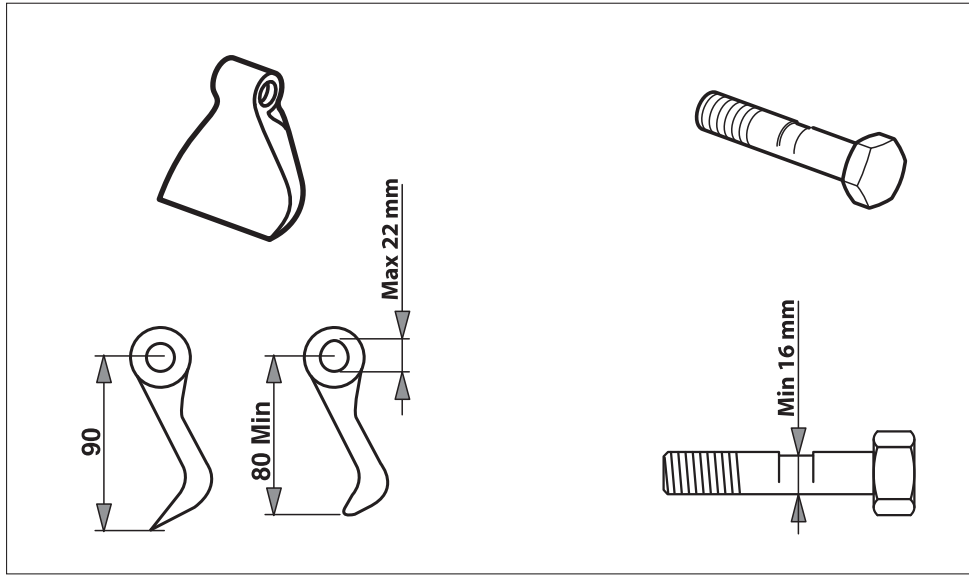

(Fig.12)

5.4. Belts: use and replacement

The transmission of motor force to the rotor is carried out by belts with recordable tensioning. Periodically, or if the belts malfunction or slip, check the tension of the transmission belts from the appropriate slit and, if necessary, replace them.

The operations to carry out are the following (**Fig.13**):

- Remove the nuts which secure the protection carter;
- Loosen bolts **A** which secure transmission box **B**;
- Loosen nuts **C** and E and use pulling screw **D** to adjust the tension of the belts.

It is advisable to be equipped with a metal ruler of an appropriate length and, resting it on the edges of the two pulleys, it must touch all four edges of the pulleys themselves.

Press on the belt, in the central area between the two pulleys, with a force of **5kg**: the force will cause a deformation on the individual belt of **1cm**.

- Tighten the screws which secure the transmission box and extension
- Remount the previously removed carter.

Used belts suffer stretching, therefore, for correct distribution of the forces, they must always be replaced together.

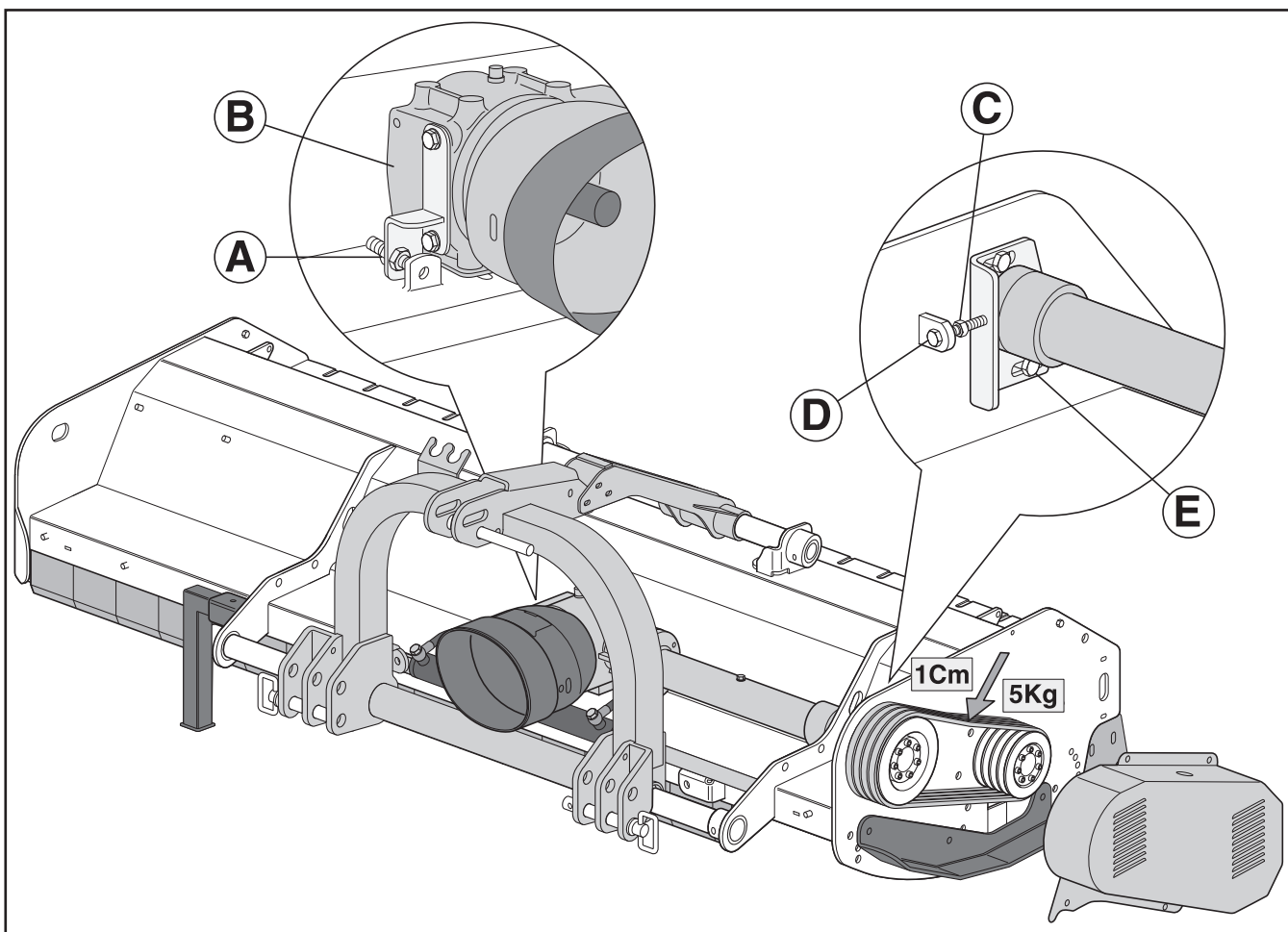

(Fig.13)

5.5. Problems and solutions

Excessive grinding of the product to be cut

- Slightly raise the mower from the ground, adjusting the height
- Increase the advancing speed

Scarce grinding of the product to be cut

- Slightly lower the mower from the ground, adjusting the height
- Decrease the advancing speed
- Do not work on ground which is too wet or muddy

Blockage of the rotor

- Ground is too wet to work on
- Raise the mower from the ground
- Reduce the advancing speed

The mower bounces on the ground or vibrates

- Foreign bodies blocked between the hummers
- Hummers incorrectly mounted, without the helical device or with the edge penetrating into the ground
- Worn or broken hummers
- Deformation of the rotor due to foreign bodies having hit the central part

Drop in rotor speed

- Belt overheating
- Record belt tension

Roller support bearing seizure

- Verify oil level
- The machine does not move sideways
- The machine does not perform the rotation movement

5.6. Set-aside

At the end of the season, or if a long rest period is necessary, it is advisable to:

- wash soil and chemical products off the mower and dry it
- check it carefully and if necessary replace damaged or worn parts
- fully tighten all screws and bolts, in particular those which secure the cutters
- perform careful greasing and finally protect all the equipment with a cover and store it in a dry place

If these operations are done with care, the user will find the mower in perfect condition when restarting work.

Remember that the Manufacturer is always available for any assistance and for spare parts.

5.7. Demolition of the mower

At the end of the working life of the whole machine, or of any worn component, see to its demolition and subsequent scrapping, contacting the Specialised Centres.



ATTENTION!

It is prohibited to neglect the machine or any of its components as some components could be dangerous or, in the case of lubricants or varnishes, could cause environmental pollution.

When demolishing the machine, it is necessary to separate the parts in plastic which must be sent to specific separate waste collections respecting the current legislation.

The metallic parts must be divided into steel parts and those made up of other metals or alloys, in order to correctly send them to be melted down.

6. WARRANTY

The constructor's warranty is valid for 12 month after the date of purchase and the following conditions apply:

- the product was not damaged during transportation and all accessories are intact and present;
- if faulty parts are duly acknowledged by the supplier, they are replaced or repaired free of charge;
- if the purchaser has respected the conditions of service of the warranty. In all cases, the purchaser is responsible for all transportation costs.

The warranty is forfeited if:

- the operator makes a mistake in manoeuvring the machine;
- repairs are carried out by the user without obtaining the Manufacturer's consent;
- replacements are made with non-original parts
- the manual's instructions are not followed
- the products is arbitrarily tampered with and changed without authorisation.

The warranty does not cover parts subject to wear from normal use, such as: counter blades, cutting blades, pinion and gears in general, electric motors and cables.

Dealers and users cannot expect any indemnity from the Manufacturer for eventual damage (labour charges, transportation, defective work, material or bodily accidents, lack of earning on the crop etc.)

All faulty parts must be made available to BE.

TFB 1200 - 3000

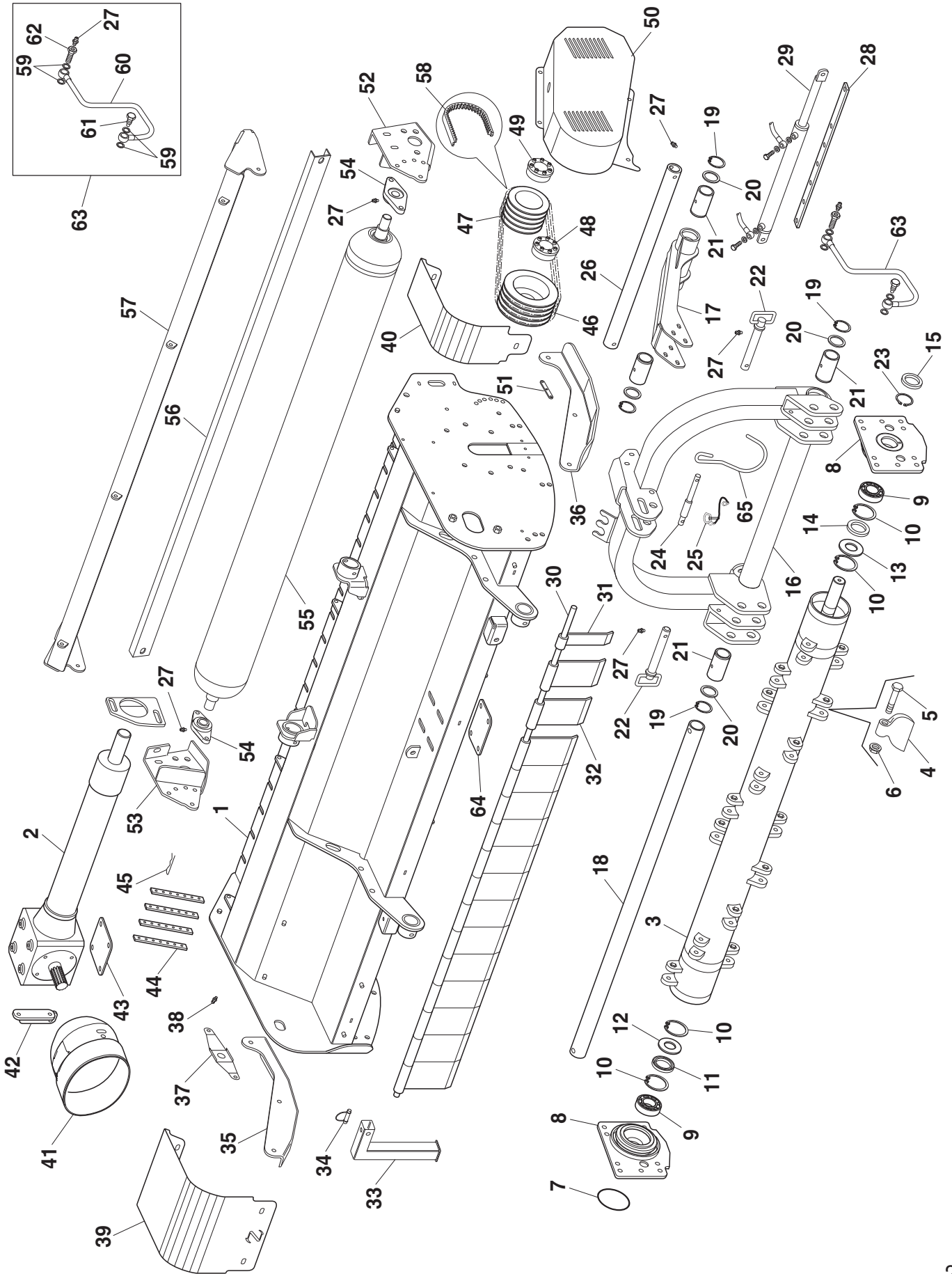

TFB 1200 - 3000

No.	Part No.	Qty	Description
1	3231244	1	COMPOSTO SCOCCA TRINCIA TFB 1200
	3231245	1	COMPOSTO SCOCCA TRINCIA TFB 1400
	3231246	1	COMPOSTO SCOCCA TRINCIA TFB 1600
	3231247	1	COMPOSTO SCOCCA TRINCIA TFB 1800
	3231248	1	COMPOSTO SCOCCA TRINCIA TFB 2000
	3231249	1	COMPOSTO SCOCCA TRINCIA TFB 2200
	3231250	1	COMPOSTO SCOCCA TRINCIA TFB 2400
	3231251	1	COMPOSTO SCOCCA TRINCIA TFB 2600
	3231252	1	COMPOSTO SCOCCA TRINCIA TFB 2800
	3231253	1	COMPOSTO SCOCCA TRINCIA TFB 3000
2	2020024	1	SCATOLA TRASMISSIONE GRANDE 500 TFB 1200-1400
	2020025	1	SCATOLA TRASMISSIONE GRANDE 615 TFB 1600-1800
	2020015	1	SCATOLA TRASMISSIONE GRANDE 780 TFB 2000
	2020088	1	SCATOLA TRASMISSIONE GRANDE 950 TFB 2200
	2020036	1	SCATOLA TRAS. 313 PR 950 (9.313.093) TFB 2400
	2020045	1	SCATOLA TRAS. 313 PR 1200 9.313.011 TFB 2600-2800
	2020043	1	SCATOLA TRAS. 313 PR 1350 9.313.012 TFB 3000
3	3231254	1	COMPOSTO ROTORE TRINCIA TFB 1200
	3231255	1	COMPOSTO ROTORE TRINCIA TFB 1400
	3231256	1	COMPOSTO ROTORE TRINCIA TFB 1600
	3231257	1	COMPOSTO ROTORE TRINCIA TFB 1800
	3231258	1	COMPOSTO ROTORE TRINCIA TFB 2000
	3231259	1	COMPOSTO ROTORE TRINCIA TFB 2200
	3231260	1	COMPOSTO ROTORE TRINCIA TFB 2400
	3231261	1	COMPOSTO ROTORE TRINCIA TFB 2600
	3231262	1	COMPOSTO ROTORE TRINCIA TFB 2800
	3231263	1	COMPOSTO ROTORE TRINCIA TFB 3000
4	5350110	10	MAZZA RMD.11 FORO D.20,5 TFB 1200
	5350110	12	MAZZA RMD.11 FORO D.20,5 TFB 1400
	5350110	14	MAZZA RMD.11 FORO D.20,5 TFB 1600
	5350110	16	MAZZA RMD.11 FORO D.20,5 TFB 1800
	5350110	18	MAZZA RMD.11 FORO D.20,5 TFB 2000
	5350110	20	MAZZA RMD.11 FORO D.20,5 TFB 2200
	5350110	20	MAZZA RMD.11 FORO D.20,5 TFB 2400
	5350110	22	MAZZA RMD.11 FORO D.20,5 TFB 2600
	5350110	24	MAZZA RMD.11 FORO D.20,5 TFB 2800
	5350110	26	MAZZA RMD.11 FORO D.20,5 TFB 3000
5	5315093	10	VITE TE M 20x123 SPECIALE 10.9 TFB 1200
	5315093	12	VITE TE M 20x123 SPECIALE 10.9 TFB 1400
	5315093	14	VITE TE M 20x123 SPECIALE 10.9 TFB 1600
	5315093	16	VITE TE M 20x123 SPECIALE 10.9 TFB 1800
	5315093	18	VITE TE M 20x123 SPECIALE 10.9 TFB 2000

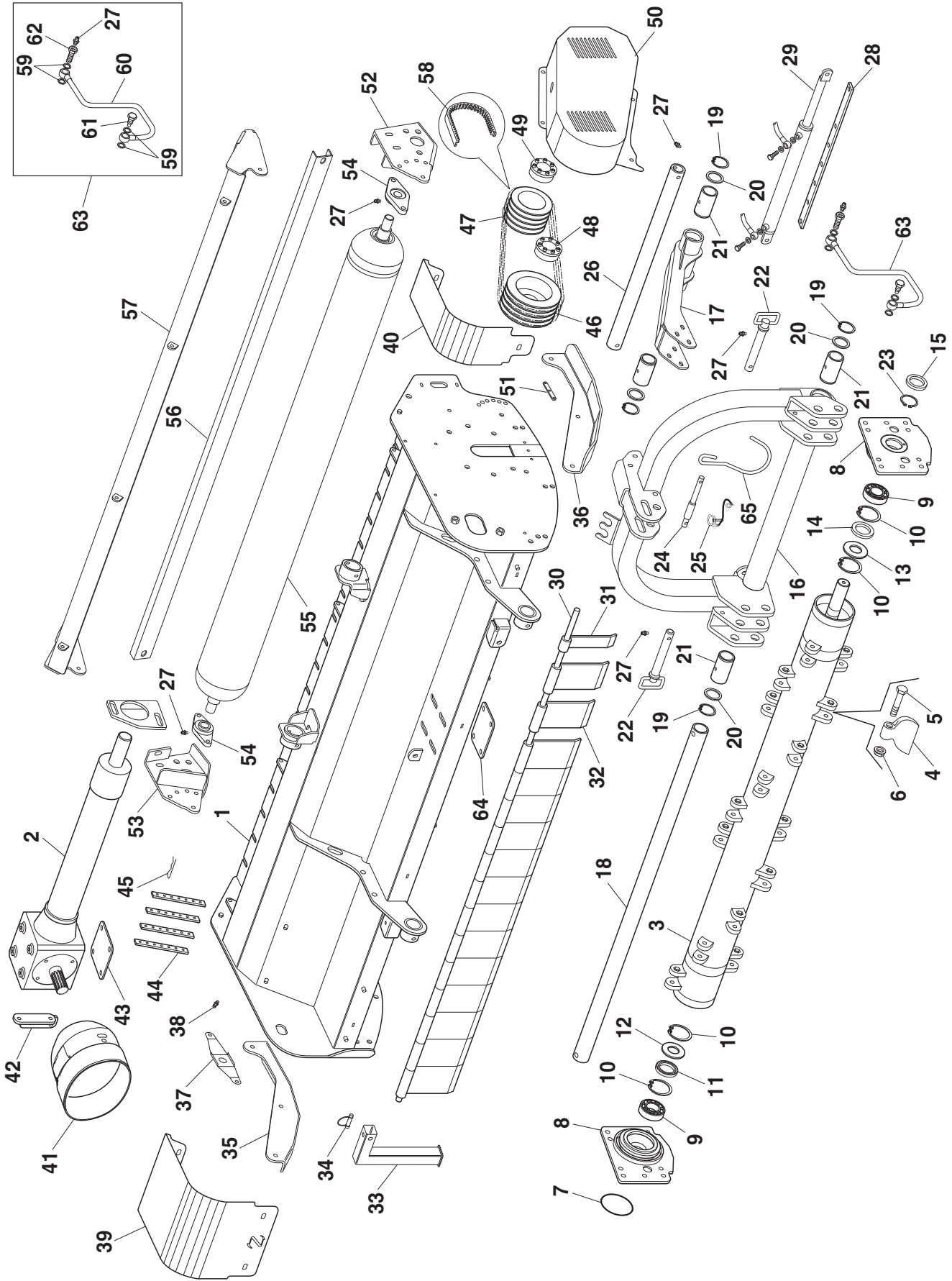

TFB 1200 - 3000

No.	Part No.	Qty	Description
	5315093	20	VITE TE M 20x123 SPECIALE 10.9 TFB 2200
	5315093	20	VITE TE M 20x123 SPECIALE 10.9 TFB 2400
	5315093	22	VITE TE M 20x123 SPECIALE 10.9 TFB 2600
	5315093	24	VITE TE M 20x123 SPECIALE 10.9 TFB 2800
	5315093	26	VITE TE M 20x123 SPECIALE 10.9 TFB 3000
6	5323018	10	DADO AUT. M 20x1,50 UNI 7474 ZBN H=20 mm TFB 1200
	5323018	12	DADO AUT. M 20x1,50 UNI 7474 ZBN H=20 mm TFB 1400
	5323018	14	DADO AUT. M 20x1,50 UNI 7474 ZBN H=20 mm TFB 1600
	5323018	16	DADO AUT. M 20x1,50 UNI 7474 ZBN H=20 mm TFB 1800
	5323018	18	DADO AUT. M 20x1,50 UNI 7474 ZBN H=20 mm TFB 2000
	5323018	20	DADO AUT. M 20x1,50 UNI 7474 ZBN H=20 mm TFB 2200
	5323018	20	DADO AUT. M 20x1,50 UNI 7474 ZBN H=20 mm TFB 2400
	5323018	22	DADO AUT. M 20x1,50 UNI 7474 ZBN H=20 mm TFB 2600
	5323018	24	DADO AUT. M 20x1,50 UNI 7474 ZBN H=20 mm TFB 2800
	5323018	26	DADO AUT. M 20x1,50 UNI 7474 ZBN H=20 mm TFB 3000
7	5385041	1	ANELLO O-RING 3,53 x 107,5 OR4425
8	3231182	2	COMPOSTO SUPPORTO CUSCINETTO LFG
9	5360038	2	CUSCINETTO 22211 55-100-25 CW33
10	5333053	4	ANELLO D'ARRESTO D.100 INT.UNI7437 DIN47
11	5380009	1	ANELLO DI TENUTA TC 55 - 100 - 10
12	5227711	1	COPERCHIO PARAOLIO Ø 55
13	5227712	1	COPERCHIO PARAOLIO Ø 60
14	5380010	1	ANELLO DI TENUTA TC 60 - 100 - 10
15	5381002	1	ANELLO DI TENUTA TC 45 - 75 - 10
16	3231264	1	COMPOSTO CASTELLO TRINCIA
17	3231265	1	COMPOSTO BRACCIO CASTELLO TRINCIA
18	5220840	1	TUBO SOSTEGNO TRINCIA TFB 1200-1400
	5220798	1	TUBO SOSTEGNO TFG 1600/3000
19	5333054	4	ANELLO D'ARRESTO D.62 INT.UNI7437 DIN472
20	5227149	4	COPERCHIETTO CASTELLO UNI
21	5400054	4	BOCCOLA NYLON MURYLON 6 D.58/51 L=80
22	5215374	2	PERNO PARALLELE TFG-TCK-TMA Art. 00009
23	5332037	1	ANELLO D'ARRESTO D.55 EST.UNI7435 DIN471
24	5215015	1	PERNO ATTACCO 3° PUNTO Art.1611
25	5341017	1	COPIGLIA A SCATTO D.10 C/TIRANTE Art.252
26	5220759	1	TUBO SOSTEGNO SECONDARIO
27	5313001	3	INGRASSATORE M 6 x 1 UNI 7663 TIPO A Z
28	5210283	1	ASTA DI POSIZIONAMENTO TFB 1200-1400
	5210223	1	ASTA DI POSIZIONAMENTO TFB 1600/3000
29	2050010	1	GRUPPO SPOSTAMENTO IDR. L.300 COMPLETO
	2050011	1	GRUPPO SPOSTAMENTO IDR. L.400 COMPLETO
30	5215446	1	TRAFILATO PORTA ALETTE TFB 1200

TFB 1200 - 3000

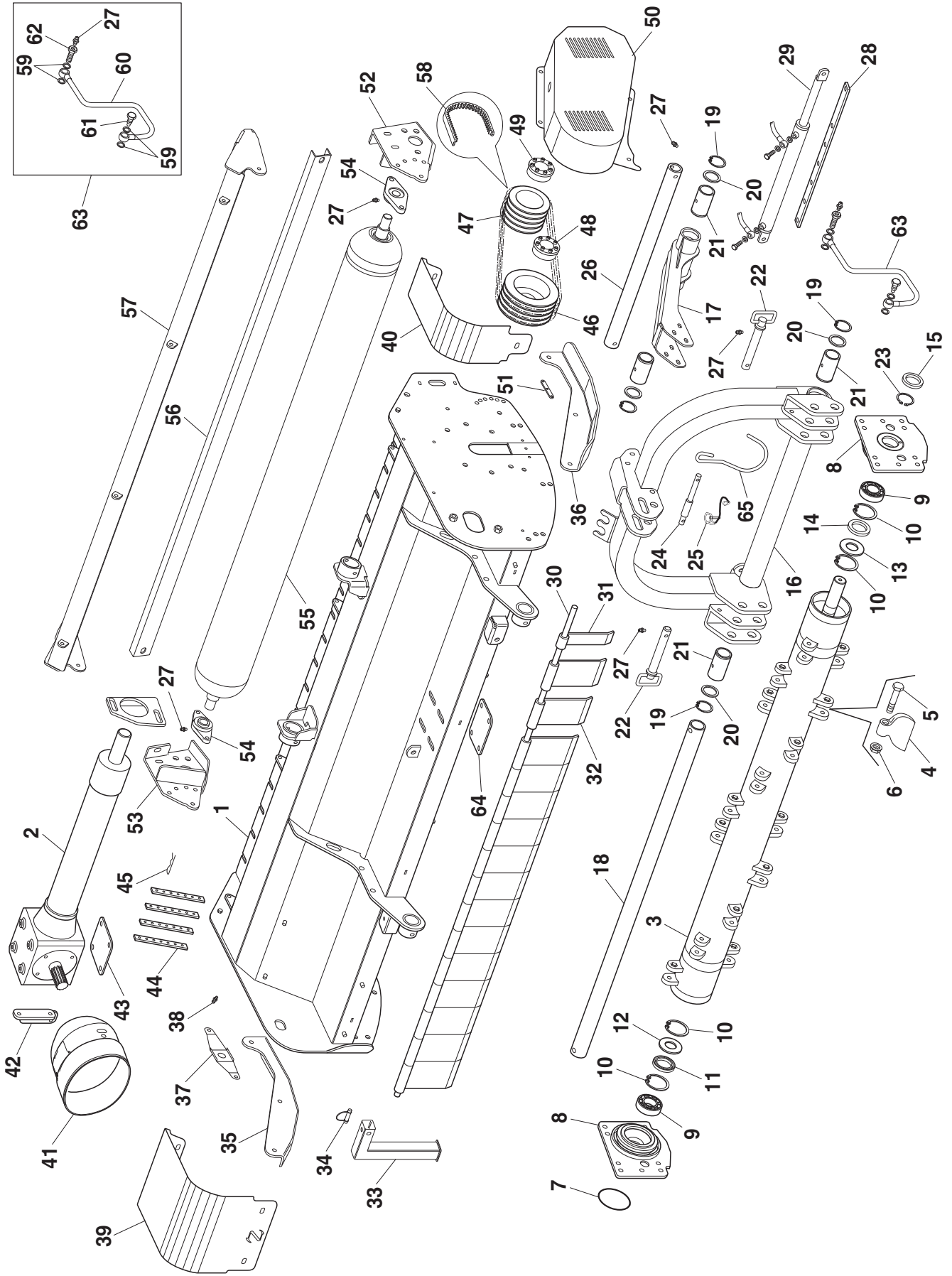

TFB 1200 - 3000

No.	Part No.	Qty	Description
	5215447	1	TRAFILATO PORTA ALETTE TFB 1400
	5215077	1	TRAFILATO PORTA ALETTE TFB 1600
	5215410	1	TRAFILATO PORTA ALETTE TFB 1800
	5215411	1	TRAFILATO PORTA ALETTE TFB 2000
	5215412	1	TRAFILATO PORTA ALETTE TFB 2200
	5215413	1	TRAFILATO PORTA ALETTE TFB 2400
	5215414	1	TRAFILATO PORTA ALETTE TFB 2600
	5215415	1	TRAFILATO PORTA ALETTE TFB 2800
	5215416	1	TRAFILATO PORTA ALETTE TFB 3000
31	5210160	2	ALETTA PROTEZIONE PICCOLA TFB 1200
	5210160	4	ALETTA PROTEZIONE PICCOLA TFB 1400
	5210160	2	ALETTA PROTEZIONE PICCOLA TFB 1600
	5210160	2	ALETTA PROTEZIONE PICCOLA TFB 1800
	5210160	1	ALETTA PROTEZIONE PICCOLA TFB 2000
	5210160	8	ALETTA PROTEZIONE PICCOLA TFB 2400
	5210160	1	ALETTA PROTEZIONE PICCOLA TFB 2600
	5210160	2	ALETTA PROTEZIONE PICCOLA TFB 3000
32	5210161	10	ALETTA PROTEZIONE GRANDE TFB 1200
	5210161	11	ALETTA PROTEZIONE GRANDE TFB 1400
	5210161	13	ALETTA PROTEZIONE GRANDE TFB 1600
	5210161	15	ALETTA PROTEZIONE GRANDE TFB 1800
	5210161	17	ALETTA PROTEZIONE GRANDE TFB 2000
	5210161	19	ALETTA PROTEZIONE GRANDE TFB 2200
	5210161	18	ALETTA PROTEZIONE GRANDE TFB 2400
	5210161	22	ALETTA PROTEZIONE GRANDE TFB 2600
	5210161	24	ALETTA PROTEZIONE GRANDE TFB 2800
	5210161	25	ALETTA PROTEZIONE GRANDE TFB 3000
33	3230240	1	COMPOSTO PIEDINO APPOGGIO TFZ
34	5341009	1	SPINOTTO DI SICUREZZA D.8 AMA 1369
35	5227919	1	SLITTA DX TRINCIA TFB
36	5227920	1	SLITTA SX TRINCIA TFB
37	5225995	1	PROTEZIONE INGRASSATORE TRINCIA
38	5313002	1	INGRASSATORE M 10x1 UNI 7663 TIPO A Z
39	5228313	1	COPRIFIANCATA GRANDE TFB 1400
	5228313	1	COPRIFIANCATA GRANDE TFB 1600
	5228313	1	COPRIFIANCATA GRANDE TFB 1800
	5228313	1	COPRIFIANCATA GRANDE TFB 2000
	5228313	2	COPRIFIANCATA GRANDE TFB 2200
	5228313	2	COPRIFIANCATA GRANDE TFB 2400
	5228313	2	COPRIFIANCATA GRANDE TFB 2600
	5228313	2	COPRIFIANCATA GRANDE TFB 2800
	5228313	2	COPRIFIANCATA GRANDE TFB 3000

TFB 1200 - 3000

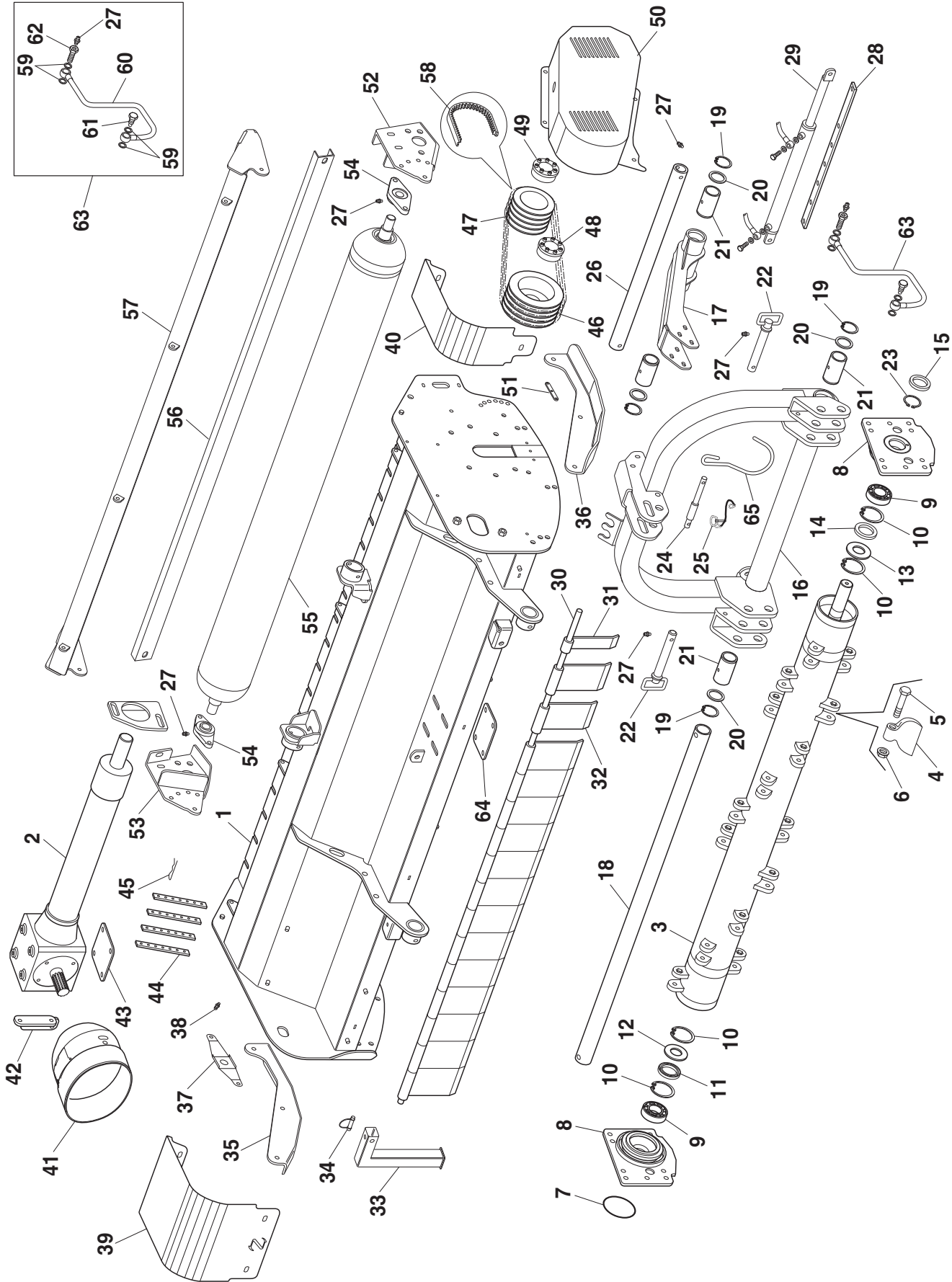

TFB 1200 - 3000

No.	Part No.	Qty	Description
40	5228314	2	COPRIFIANCATA PICCOLA TFB 1200
	5228314	1	COPRIFIANCATA PICCOLA TFB 1400
	5228314	1	COPRIFIANCATA PICCOLA TFB 1600
	5228314	1	COPRIFIANCATA PICCOLA TFB 1800
	5228314	1	COPRIFIANCATA PICCOLA TFB 2000
41	5400112	1	CUFFIA PROTEZIONE CARDANO Art. 36/211
42	5228311	1	TIRANTE PER COPPIA
43	5228312	1	SPESSORE SCATOLA TFB 1200/2200
44	5210142	10	ASTA RACCOLTA SARMENTI TFB 1200
	5210142	12	ASTA RACCOLTA SARMENTI TFB 1400
	5210142	14	ASTA RACCOLTA SARMENTI TFB 1600
	5210142	16	ASTA RACCOLTA SARMENTI TFB 1800
	5210142	18	ASTA RACCOLTA SARMENTI TFB 2000
	5210142	19	ASTA RACCOLTA SARMENTI TFB 2200
	5210142	20	ASTA RACCOLTA SARMENTI TFB 2400
	5210142	21	ASTA RACCOLTA SARMENTI TFB 2600
	5210142	22	ASTA RACCOLTA SARMENTI TFB 2800
	5210142	24	ASTA RACCOLTA SARMENTI TFB 3000
45	5341013	10	SPINA BETA D.5 Art. 27 TFB 1200
	5341013	12	SPINA BETA D.5 Art. 27 TFB 1400
	5341013	14	SPINA BETA D.5 Art. 27 TFB 1600
	5341013	16	SPINA BETA D.5 Art. 27 TFB 1800
	5341013	18	SPINA BETA D.5 Art. 27 TFB 2000
	5341013	19	SPINA BETA D.5 Art. 27 TFB 2200
	5341013	20	SPINA BETA D.5 Art. 27 TFB 2400
	5341013	21	SPINA BETA D.5 Art. 27 TFB 2600
	5341013	22	SPINA BETA D.5 Art. 27 TFB 2800
	5341013	24	SPINA BETA D.5 Art. 27 TFB 3000
46	5353011	1	PULEGGIA VIBIK SPB D.180/G2 f.80 TFB 1200
	5353015	1	PULEGGIA VIBIK SPB D.180/G3 f.80 TFB 1400-1600
	5353056	1	PULEGGIA VIBIK SPB D.180/G4 f.80 TFB 1800-2000
	5353057	1	PULEGGIA VIBIK SPB D.180/G5 f.80 TFB 2200-2400
	5353070	1	PULEGGIA VIBIK SPB D.180/G6 f.80 TFB 2600-2800-3000
47	5353012	1	PULEGGIA VIBIK SPB D.130/G2 f.80 TFB 1200
	5353016	1	PULEGGIA VIBIK SPB D.130/G3 f.80 TFB 1200-1400
	5353054	1	PULEGGIA VIBIK SPB D.130/G4 f.80 TFB 1800-2000
	5353055	1	PULEGGIA VIBIK SPB D.130/G5 f.80 TFB 2200-2400
	5353069	1	PULEGGIA VIBIK SPB D.130/G6 f.80 TFB 2600-2800-3000
48	5356001	1	CALETTATORE VIBLOCK 156 D.40x80 TFZ
49	5356002	1	CALETTATORE VIBLOCK 156 D.45x80 TFZ
50	3231266	1	COMPOSTO CARTER BASSO TFB 1200/2000
	3231267	1	COMPOSTO CARTER ALTO TFB 2200/3000

TFB 1200 - 3000

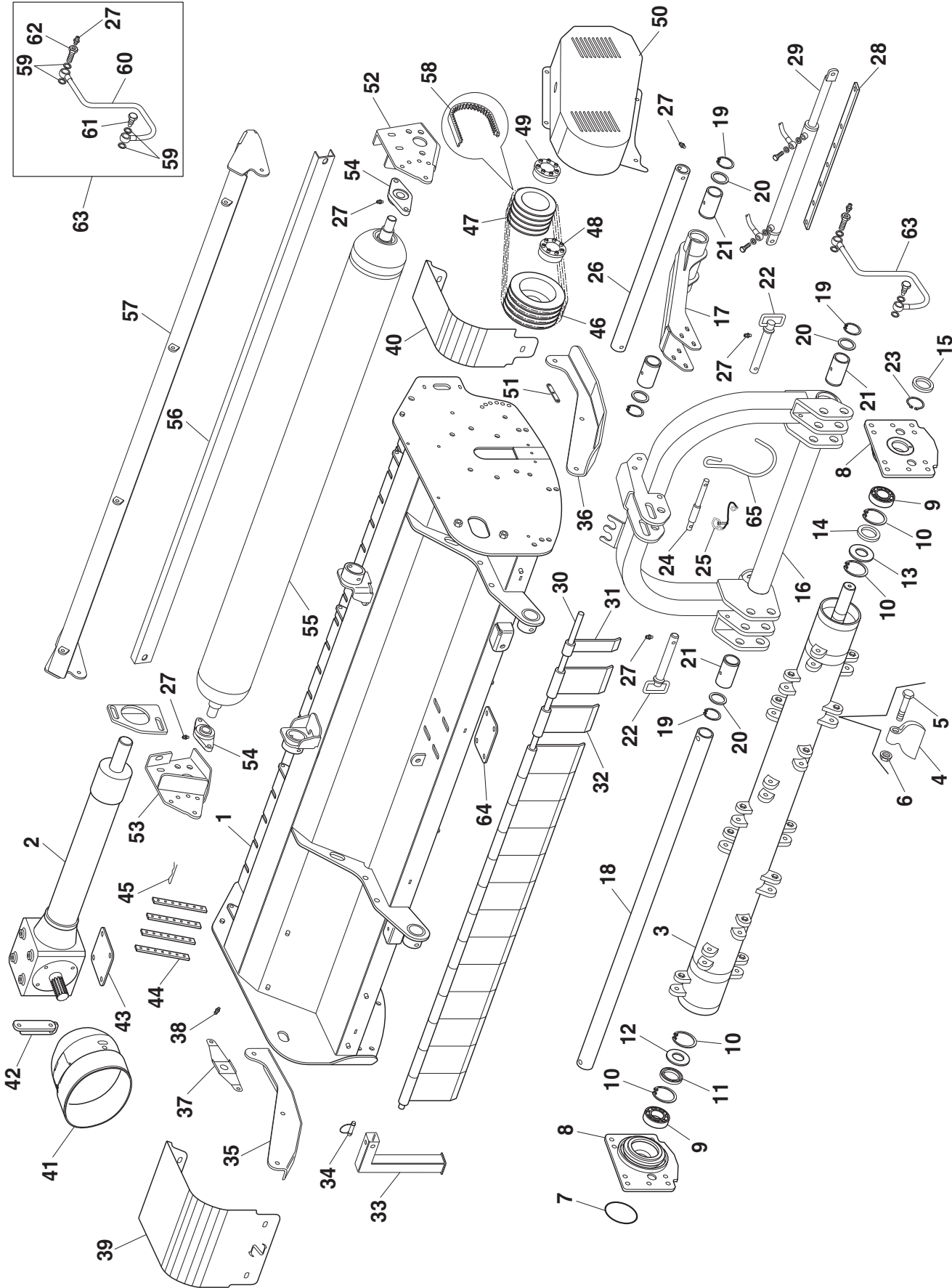

TFB 1200 - 3000

No.	Part No.	Qty	Description
51	5227390	1	ATTACCO PROTEZIONE TSS
52	3231191	1	COMP. SUPP. RULLO FOLLE SX TFB 1200/2200
	3231135	1	COMP. SUPP. RULLO FOLLE SX TFB 2400/3000
53	3231190	1	COMP. SUPP. RULLO FOLLE DX TFB 1200/2200
	3231134	1	COMP. SUPP. RULLO FOLLE DX TFB 2400/3000
54	5364004	1	CUSCINETTO UCFL 206 con fori d.16
55	3231148	1	COMPOSTO RULLO OZIOSO TFB 1200
	3230598	1	COMPOSTO RULLO OZIOSO TFB 1400
	3231150	1	COMPOSTO RULLO OZIOSO TFB 1600
	3231151	1	COMPOSTO RULLO OZIOSO TFB 1800
	3231152	1	COMPOSTO RULLO OZIOSO TFB 2000
	3231153	1	COMPOSTO RULLO OZIOSO TFB 2200
	3231154	1	COMPOSTO RULLO OZIOSO TFB 2400
	3231155	1	COMPOSTO RULLO OZIOSO TFB 2600
	3231156	1	COMPOSTO RULLO OZIOSO TFB 2800
	3231157	1	COMPOSTO RULLO OZIOSO TFB 3000
56	3231159	1	COMPOSTO RASCHIAFANGO TFB 1200
	3231160	1	COMPOSTO RASCHIAFANGO TFB 1400
	5213022	1	COMPOSTO RASCHIAFANGO TFB 1600
	5213023	1	COMPOSTO RASCHIAFANGO TFB 1800
	5213006	1	COMPOSTO RASCHIAFANGO TFB 2000
	5213025	1	COMPOSTO RASCHIAFANGO TFB 2200
	5213026	1	COMPOSTO RASCHIAFANGO TFB 2400
	5213027	1	COMPOSTO RASCHIAFANGO TFB 2600
	5213028	1	COMPOSTO RASCHIAFANGO TFB 2800
	5213029	1	COMPOSTO RASCHIAFANGO TFB 3000
57	3231137	1	COMPOSTO PORTELLONE TFB 1200
	3231138	1	COMPOSTO PORTELLONE TFB 1400
	3231139	1	COMPOSTO PORTELLONE TFB 1600
	3231140	1	COMPOSTO PORTELLONE TFB 1800
	3231141	1	COMPOSTO PORTELLONE TFB 2000
	3231142	1	COMPOSTO PORTELLONE TFB 2200
	3231143	1	COMPOSTO PORTELLONE TFB 2400
	3231144	1	COMPOSTO PORTELLONE TFB 2600
	3231145	1	COMPOSTO PORTELLONE TFB 2800
	3231146	1	COMPOSTO PORTELLONE TFB 3000
58	5354049	2	CINGHIA SPB 1340 Dentellata TFB 1200
	5354049	3	CINGHIA SPB 1340 Dentellata TFB 1400-1600
	5354049	4	CINGHIA SPB 1340 Dentellata TFB 1800-2000
	5354049	5	CINGHIA SPB 1340 Dentellata TFB 2200-2400
	5354049	6	CINGHIA SPB 1340 Dentellata TFB 2600-2800-3000
59	5429014	4	RONDELLA IN RAME DA M10

TFB 1200 - 3000

